

HF series

Proportional multi-axis fingertip controllers •
non-contacting Hall effect technology



DISTINCTIVE FEATURES

One, two or three axis

Analog outputs

CAN bus J1939 and CANopen options

USB 2.0 HID interface options

Connectorized housing



ENVIRONMENTAL SPECIFICATIONS

- Operating Temperature: -40 °C to +85 °C (-40 °F to +185 °F)
- Storage Temperature: -40 °C to +85 °C (-40 °F to +185 °F)
- Above Panel Sealing: Up to IP67 (subject to final specifications)
- EMC Immunity Level (V/M): EN61000-4-3
- EMC Emissions Level: EN61000-6-3:2001
- ESD: EN61000-4-3 Level 2 (±4 kv contact, ± 6 kv air)
- Output linearity: ±200 mV
- Dual output interlinearity (X/Y): ±400 mV
- Dual output interlinearity (Z): ±600 mV



SENSOR SPECIFICATIONS

- Sensor: Hall effect, single or dual
- Supply Voltage Range: 5 VDC ±0.01 VDC
- Supply Current: 40 mA typical / 50 mA max (3 axis)
- Reverse Polarity Max: -10 VDC
- Transient Overvoltage Max: 16 VDC
- Ratiometric Output Voltage: see output options
- Output Current: 8 mA
- Output Load: 1 K ohm min
- Output Impedance: 2 Ω



MATERIALS

- Shaft: Stainless Steel
- Boot: Silicone
- Handles: Glass filled nylon*
- Body: Glass filled nylon

The company reserves the right to change specifications without notice.



HF series

Proportional multi-axis fingertip controllers • non-contacting Hall effect technology



TERMINATION (ANALOG OUTPUTS ONLY)

- The HF series (Output options 0-11) features a Hirose DF11-12DP-2DS9 (24) header (male receptacle) (Fig 1)
- The mating harness is not included but may be specified at the time of order. Contact your APEM sales representative. This optional harness features a Hirose DF11-12DS-2C connector (female socket)(Fig. 2) to individual stripped and tinned wire leads.
- Header specifications: 12 position, 2mm pitch dual row (2x6) pin header
- Wire harness specifications: 22AWG Teflon, 25cm multi-conductor with heat shrink. Hirose DF11-12DS-2C to stripped and tinned wire leads



Fig. 1
Hirose DF11-12DP-2DS9(24) header



Fig. 2
Mating wire harness fitted with Hirose DF11-12DS-2C connector

* Most handles, dependent upon configurations

JOYSTICK HEADER - HIROSE DF11-12DP-2DS9 (24) PINOUT (FIG 1)

PIN 2	PIN 4	PIN 6	PIN 8	PIN 10	PIN 12
RED	BLUE	YELLOW	GREEN	WHITE	--
BLACK	BLU/WHT	YEL/BLK	GRN/BLK	ORANGE	VIOLET
PIN 1	PIN 3	PIN 5	PIN 7	PIN 9	PIN 11

MATING WIRE HARNESS COLOR DEFINITION (FIG 2)

HIROSE DF11-12DS-2C CONNECTOR PIN #	WIRE COLOR	JOYSTICK FUNCTION
1	Black	Ground
2	Red	Supply power
3	Blue / white	X axis (dual output)
4	Blue	X axis
5	Yellow / black	Y axis (dual output)
6	Yellow	Y axis
7	Green / black	Z axis (dual output)
8	Green	Z axis
9	Orange	Button one
10	White	Button common
11	Violet	Button two
12	--	--



MECHANICAL SPECIFICATIONS

X/Y AXIS

- Break Out Force: 1.3 N (0.3 lbf)
- Operating Force: 2.8 N (0.63 lbf)
- Expected Mechanical Life: 5 million lifecycles
- Lever Action: Single spring, omnidirectional
- Deflection Angle:

Limiter plate	Cardinal axis (±)	Diagonal axis (±)
Square / Diamond	13.5°	20
Circular	15.8°	n/a
Slot X	15.8°	n/a
Slot Y	15.8°	n/a
Cross	15.8°	n/a

Z AXIS

- Break Out Torque: 0.09 Nm (0.80 lbf in)
- Operating Torque: 0.121 Nm (1.07 lbf in)
- Degrees of rotation: 60° (30° from center)
- Expected Mechanical Life: 5 million lifecycles
- Handle Action: Spring centering

Proportional multi-axis fingertip controllers • non-contacting Hall effect technology



GENERAL MOUNTING OPTIONS

DROP-IN MOUNT

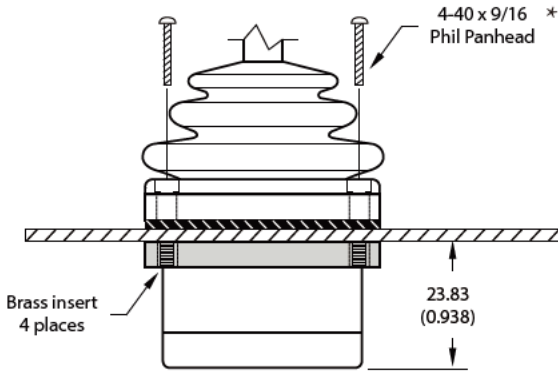

REAR MOUNT

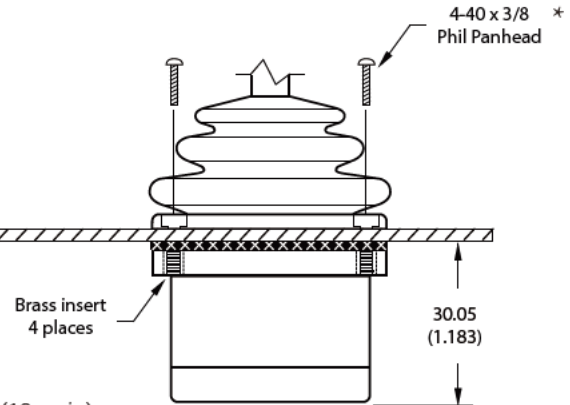

* = Recommended maximum torque: 0.1 - 0.125 Nm evenly per screw (18 oz-in).



PANEL CUT-OUT

DROP-IN MOUNT

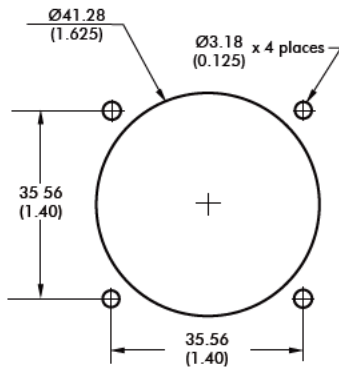

CLAMPING RING

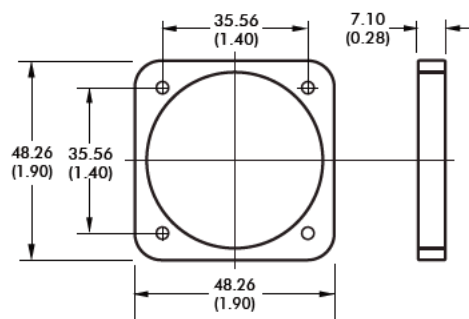

REAR MOUNT

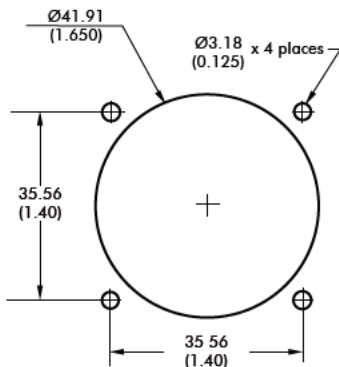

AXIS ORIENTATION

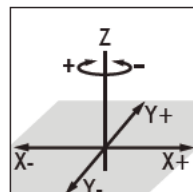

NOTES:

- For DROP-IN mounting, panel thickness can be 1.17 mm to 3.17 mm (0.046 in to 0.125 in).
- For REAR MOUNT, the maximum panel thickness is 1.6 mm (0.063 in).
- A panel thickness of 1/16" (1.6 mm/0.063 in) was considered for all below panel depth values.
- The below panel depth is extended by 7.11 mm (0.28 in) with the USB, Cursor Emulation, Voltage Regulator options.

Not available for option 55 handles

HF series

Proportional multi-axis fingertip controllers • non-contacting Hall effect technology



CAN J1939 INTERFACE SPECIFICATION

The HF Series joystick can be configured with a maximum of three axis and two buttons. All axis and button data are delivered on a CAN 2.0B compliant physical interface. Two additional signals allow configuration of the controller Source Address. Controller messages are delivered per the SAE J1939-71 message protocol.

CAN 2.0B INTERFACE PARAMETERS

- Baud rate: 250 kbps
- Transmission repetition rate: 50ms
- BJMI/EJMI interval time: 20ms
- Terminating resistor: No (available by special request to factory)

CAN MESSAGE PROTOCOL

- Primary Axis and button data on Basic Joystick Message 1 (BJM1):
 - Priority: 3
 - Base PGN: 0xFDD6
 - Source address: 0x16
 - Data field: 8 bytes
- Z-Axis data on Extended Joystick Message 1 (EJMI):
 - Priority: 3
 - Base PGN: 0xFDD7
 - Source address: 0x16
 - Data field: 8 bytes

CAN MESSAGE ADDRESSES

Alternate source addresses may be selected by grounding combinations of the blue and/or orange wires. For further information, please see TERMINATION on page 6.

CAN SOURCE ADDRESS	ORANGE WIRE	BLUE WIRE
0x13 (default)	OPEN	OPEN
0x23	OPEN	Grounded
0x33	Grounded	OPEN
0x43	Grounded	Grounded

BJM1 DATA FIELD STRUCTURE:

START POSITION (BYTE/BIT)	LENGTH (BITS)	FUNCTION
1/1	2	Primary X-axis neutral position status
1/3	2	Primary X-axis left position status
1/5	2	Primary X-axis right position status
1/7 to 2/8	10	Primary X-axis position data
3/1	2	Primary Y-axis neutral position status
3/3	2	Primary Y-axis down position status
3/5	2	Primary Y-axis up position status
3/7 to 4/8	10	Primary Y-axis position data
6/5	2	Button 2 status
6/7	2	Button 1 status

EJMI DATA FIELD STRUCTURE:

START POSITION (BYTE/BIT)	LENGTH (BITS)	FUNCTION
5/1	2	Primary Z-axis neutral position status
5/3	2	Primary Z-axis counter-clockwise position status
5/5	2	Primary Z-axis clockwise position status
5/7 TO 6/8	10	Primary Z-axis position data

CUSTOM CAN BUS J1939 FIRMWARE*

- Baud rate: 125 kbps, 500 kbps, 1Mbps (250 kbps default)
- Custom CAN addresses
- Custom CAN bus output

* Custom CAN bus firmware available upon request.

Proportional multi-axis fingertip controllers • non-contacting Hall effect technology



CANOPEN INTERFACE SPECIFICATION

CANOPEN INTERFACE PARAMETERS*

- Baud rate: 250 kbps
- Node ID: 20h
- Buttons: 1A0H (180H + NODE ID)
- Analog (axis) outputs: 2A0h (280h + Node ID)
- Heartbeat (500ms): 720h (700h + Node ID)
- Axis resolution: 8 bit
- Network Management: Auto start enabled

CANOPEN NODE ID SELECTION

Alternate NODE IDs may be selected by grounding the blue and/or orange wires. For further information, please see TERMINATION on page 6.

NODE ID SELECT	ORANGE WIRE	BLUE WIRE
20H (default)	OPEN	OPEN
21H	OPEN	Grounded
22H	Grounded	OPEN
23H	Grounded	Grounded

CANOPEN BUTTON OUTPUT CONFIGURATION

BUTTON STATUS IS TRANSMITTED IN THE ONE BYTE DATA FIELD OF FRAMES WITH AN IDENTIFIER OF 1A0 (DEFAULT)	
Identifier	Byte 0
1A0	Buttons (2:0)

CANOPEN ANALOG OUTPUT CONFIGURATION

EIGHT BIT ANALOG DATA IS TRANSMITTED IN THE THREE BYTE DATA FIELD OF FRAMES WITH AN IDENTIFIER OF 2A0 (DEFAULT)			
Identifier	Byte 0	Byte 1	Byte 2
2A0	A_IN0 (7:0)	A_IN1 (7:0)	A_IN2 (7:0)

CUSTOM CANOPEN FIRMWARE*

- Baud rate: 125 kbps, 500 kbps, 1Mbps (250 kbps default)
- Custom Node IDs (default 20 hexadecimal)
- 10-bit axis resolution
- 12-bit axis resolution
- Signed resolution
- Custom CANopen output



CANOPEN LSS INTERFACE SPECIFICATION

The CANopen LSS interface option follows the CiA305 and CiA401 standards for CAN in automation. The node ID, baud rate and additional configurations can be set and stored in the EEPROM by Service Data Object. The default settings are as follows:



CANOPEN LSS INTERFACE SPECIFICATION

CANOPEN INTERFACE PARAMETERS*

- Baud rate: 250 kbps
- Node ID: 20h (default)
- Buttons: 1A0H (180H + NODE ID)
- Analog (axis) outputs: 2A0h (280h + Node ID)
- Heartbeat (500ms): 720h (700h + Node ID)
- Axis resolution: 10-bit
- Network Management: Auto start enabled

CANOPEN LSS BUTTON OUTPUT CONFIGURATION

BUTTON STATUS IS TRANSMITTED IN THE ONE BYTE DATA FIELD OF FRAMES WITH AN IDENTIFIER OF 1A0 (DEFAULT)	
Identifier	Byte 0
1A0	Buttons (2:0)

CANOPEN LSS ANALOG OUTPUT CONFIGURATION

TEN BIT ANALOG DATA IS TRANSMITTED IN THE SIX BYTE DATA FIELD OF FRAMES WITH AN IDENTIFIER OF 2A0 (DEFAULT)			
Identifier	Byte 0	Byte 1	Byte 2
2A0	A_IN0 (7:0)	A_IN0 (9:8)	A_IN1 (7:0)
Identifier	Byte 3	Byte 4	Byte 5
2A0	A_IN1 (9:8)	A_IN2 (7:0)	A_IN2 (9:8)

* Custom CAN bus firmware available upon request.

HF series

Proportional multi-axis fingertip controllers • non-contacting Hall effect technology

TERMINATION (CAN OUTPUTS ONLY)

- HF series joysticks configured with CAN outputs (Output options 2C and 3C **only**) feature a **JST B6B-PH-S(LF)(SN)** header (male receptacle) (Fig 1) and are supplied with a mating wire harness (Fig 2)
- Header specifications: JST B6B-PH-S(LF)(SN) - 6 position, 2mm pitch, single row header (Fig 1)
- Mating wire harness specifications: Six conductor, 22 AWG, 56 cm PTFE, JST PHR-6 to stripped and tinned wire leads (Fig 2)

Fig. 1

Fig. 2

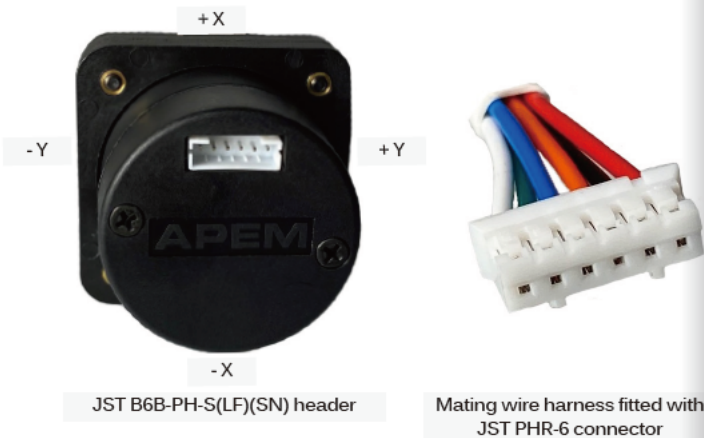

HEADER PINOUT AND MATING WIRE HARNESS COLOR DEFINITION

JST B6B-PH-S(LF)(SN) HEADER PIN #	HEADER PINOUT		MATING WIRE HARNESS
	CAN BUS FUNCTION	CANOPEN FUNCTION	WIRE COLOR
1	Supply power (7 to 35 VDC)	Supply power (7 to 35 VDC)	Red
2	Ground	Ground	Black
3	ID select MSB	Node ID select MSB	Orange
4	ID select LSB	Node ID select LSB	Blue
5	CAN Hi	CAN Hi	Green
6	CAN Lo	CAN Lo	White

* Custom CAN bus firmware available upon request.

CANOPEN LSS INTERFACE SPECIFICATIONS

The CANopen LSS interface option follows the CiA305 and CiA401 standards for CAN in automation. The node ID, baud rate and additional configurations can be set and stored in the EEPROM by Service Data Object. The default settings are as follows:

SETTINGS	DEFAULT CONFIGURATION
Baud rate	250 kbits/s
Node ID	20h
Analog (axis) outputs	2A0h (280h + Node ID)
Buttons	1A0h (180h + Node ID)
Heartbeat (500ms)	720h (700h + Node ID)
Axis Resolution	Unsigned 10-bit

CAN BUS SPECIFICATIONS

DIMENSIONS

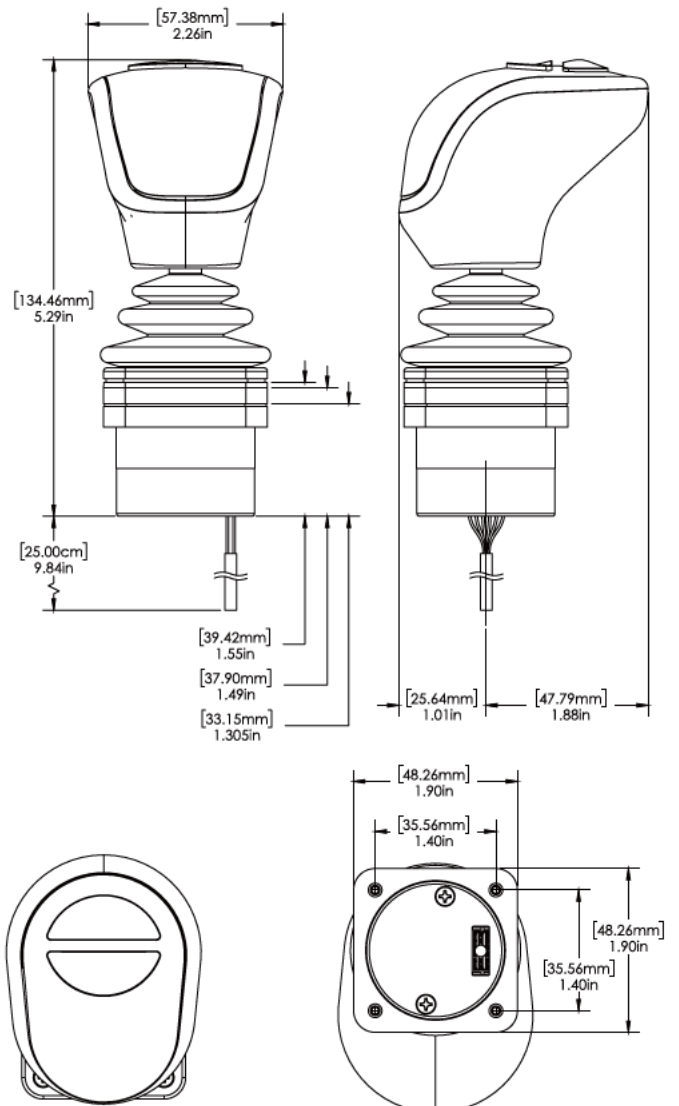

Proportional multi-axis fingertip controllers •
non-contacting Hall effect technology



USB SPECIFICATIONS

- Supply Voltage Range: 5.00 VDC
- Maximum current: 70 mA
- USB version: 2.0

USB GAME CONTROLLER

Featuring USB 2.0 HID compliant interface, APEM's USB joysticks are recognized as standard HID "game controller" devices. Adhering to the HID specification, APEM's USB joysticks are plug-and-play with most versions of Windows. Joystick button and axis assignments are dependent upon the controlled application.

Features

- USB 2.0 HID compliant "game controller" device
- Easy to install and operate
- Functions determined by controlled application
- 12-bit (0 to 4095) axis resolution

Termination (supplied cable)

- USB Male Type A Connector (198 cm)
 - (72" +/-1") - overmolded cabled - Mini B to Male Type A USB connector (option 0U)
 - (84" +/-1") - overmolded cable - Male Type A USB connector (option 2U)

USB CURSOR EMULATION

The Cursor Emulation option converts multi-axis joystick output into a mouse or cursor control device. The Cursor Emulation option is ideal for vehicle applications subjected to dirt and high vibration which makes operating a traditional cursor control device difficult. Cursor simulation is only compatible with Window OS.

Features

- HID compliant "mouse" device

Button Function

- B1: Left Mouse Click
- B2: Right Mouse Click

Termination (supplied cable)

- USB Male Type A Connector (185 cm):
 - (72" +/-1") - overmolded cabled - Mini B to Male Type A USB connector (option 0U)

SUPPORTED OPERATING SYSTEMS: USB GAME CONTROLLER AND CURSOR EMULATION

Windows Operating System

- Windows 7
- Windows 8.1
- Windows 10

Linux Operating System

APEM's USB joysticks are compatible with Linux, although system compatibility is not guaranteed. The user is responsible for verifying specific Linux OS compatibility.

Custom Firmware

Custom configurations and firmware is available upon request. Available options include:

- 8-bit axis resolution
- 10-bit axis resolution
- Signed bit axis resolution
- Custom USB product name

HF series

Proportional multi-axis fingertip controllers • non-contacting Hall effect technology



VOLTAGE REGULATOR SPECIFICATIONS

The Voltage Regulator allows APEM's Hall effect joysticks to operate with a range of supply voltages..

Voltage Regulator - Unipolar

- Supply Voltage Range: 8-35 VDC
- Output Voltage Range: see output options
- Maximum Current: 90 mA

Voltage Regulator - Bipolar

- Supply Voltage Range: 11-35 VDC
- Output Voltage Range: ± 10 VDC
- Maximum Current: 90 mA

Termination (flying leads)

- 28 AWG 20.32 cm (8.0") ± 1.54 cm (1") PTFE

WIRE DEFINITION)

WIRE COLOR	JOYSTICK FUNCTION
Black	Ground
Red	Supply power
Blue / white	X axis (dual output)
Blue	X axis
Yellow / black	Y axis (dual output)
Yellow	Y axis
Green / black	Z axis (dual output)
Green	Z axis
Orange	Button one
White	Button common
Violet	Button two

HF series

Proportional multi-axis fingertip controllers • non-contacting Hall effect technology



BUILD YOUR PART NUMBER

SERIES	HANDLE	LIMITER PLATE	MOUNTING	TERMINATION ⁸	ADDITIONAL																																																																		
HF																																																																							
	<table border="1"> <tr><td>10</td><td>Ball tip (2 axis)</td></tr> <tr><td>11</td><td>Tapered (2 axis)</td></tr> <tr><td>22</td><td>1 Pushbutton (2 axis)</td></tr> <tr><td>27</td><td>1 Pushbutton (2 axis), IP67 sealed</td></tr> <tr><td>33</td><td>3 Axis</td></tr> <tr><td>44</td><td>1 Pushbutton (3 axis)</td></tr> <tr><td>45</td><td>2 Pushbuttons (3 axis)</td></tr> <tr><td>46</td><td>Low profile (3 axis)</td></tr> <tr><td>50</td><td>3 Axis, IP67 Sealed</td></tr> <tr><td>51</td><td>3 Axis, 1 Pushbutton, IP67 sealed</td></tr> <tr><td>52</td><td>3 Axis, 2 Pushbuttons, IP67 sealed</td></tr> <tr><td>55</td><td>3 Axis, 2 Pushbuttons, IP67 sealed</td></tr> <tr><td>56</td><td>3 Axis, IP67 sealed</td></tr> </table>	10	Ball tip (2 axis)	11	Tapered (2 axis)	22	1 Pushbutton (2 axis)	27	1 Pushbutton (2 axis), IP67 sealed	33	3 Axis	44	1 Pushbutton (3 axis)	45	2 Pushbuttons (3 axis)	46	Low profile (3 axis)	50	3 Axis, IP67 Sealed	51	3 Axis, 1 Pushbutton, IP67 sealed	52	3 Axis, 2 Pushbuttons, IP67 sealed	55	3 Axis, 2 Pushbuttons, IP67 sealed	56	3 Axis, IP67 sealed	<table border="1"> <tr><td>S</td><td>Square</td><td>□</td></tr> <tr><td>D</td><td>Diamond</td><td>◇</td></tr> <tr><td>R</td><td>Round</td><td>○</td></tr> <tr><td>X</td><td>Slotted</td><td>—</td></tr> <tr><td>Y</td><td>Slotted</td><td>∥</td></tr> <tr><td>P</td><td>Plus</td><td>+</td></tr> <tr><td>C</td><td>Cross</td><td>×</td></tr> <tr><td>W</td><td>Guided Feel Square</td><td></td></tr> <tr><td>Z</td><td>Guided Feel Round</td><td></td></tr> <tr><td>L</td><td>Locked X and Y axis⁷</td><td></td></tr> </table>	S	Square	□	D	Diamond	◇	R	Round	○	X	Slotted	—	Y	Slotted	∥	P	Plus	+	C	Cross	×	W	Guided Feel Square		Z	Guided Feel Round		L	Locked X and Y axis ⁷		<table border="1"> <tr><td>1</td><td>Drop-in</td></tr> <tr><td>4</td><td>Rear Mount[*]</td></tr> </table> <p>[*] Rear mount not available w th handles 55 & 56</p>	1	Drop-in	4	Rear Mount [*]	<table border="1"> <tr><td>NONE</td><td>Output option (0 - 11), mating wire harness not included</td></tr> <tr><td>A</td><td>Output options (0 - 11), harness included</td></tr> </table>	NONE	Output option (0 - 11), mating wire harness not included	A	Output options (0 - 11), harness included	<table border="1"> <tr><td>R</td><td>Restricted / locked Z axis⁹</td></tr> </table>	R	Restricted / locked Z axis ⁹
10	Ball tip (2 axis)																																																																						
11	Tapered (2 axis)																																																																						
22	1 Pushbutton (2 axis)																																																																						
27	1 Pushbutton (2 axis), IP67 sealed																																																																						
33	3 Axis																																																																						
44	1 Pushbutton (3 axis)																																																																						
45	2 Pushbuttons (3 axis)																																																																						
46	Low profile (3 axis)																																																																						
50	3 Axis, IP67 Sealed																																																																						
51	3 Axis, 1 Pushbutton, IP67 sealed																																																																						
52	3 Axis, 2 Pushbuttons, IP67 sealed																																																																						
55	3 Axis, 2 Pushbuttons, IP67 sealed																																																																						
56	3 Axis, IP67 sealed																																																																						
S	Square	□																																																																					
D	Diamond	◇																																																																					
R	Round	○																																																																					
X	Slotted	—																																																																					
Y	Slotted	∥																																																																					
P	Plus	+																																																																					
C	Cross	×																																																																					
W	Guided Feel Square																																																																						
Z	Guided Feel Round																																																																						
L	Locked X and Y axis ⁷																																																																						
1	Drop-in																																																																						
4	Rear Mount [*]																																																																						
NONE	Output option (0 - 11), mating wire harness not included																																																																						
A	Output options (0 - 11), harness included																																																																						
R	Restricted / locked Z axis ⁹																																																																						
			OUTPUT OPTIONS ¹																																																																				
			<table border="1"> <tr><td>0</td><td>0V-5V</td></tr> <tr><td>1</td><td>0.5V-4.5V</td></tr> <tr><td>2</td><td>0.25V-4.75V</td></tr> <tr><td>3</td><td>1V-4V</td></tr> <tr><td>4</td><td>0V to 5V - Sensor 1 0V to 5V - Sensor 2</td></tr> <tr><td>5</td><td>0.5V to 4.5V - Sensor 1 0.5V to 4.5V - Sensor 2</td></tr> <tr><td>6</td><td>0.25V to 4.75V - Sensor 1 0.25V to 4.75V - Sensor 2</td></tr> <tr><td>7</td><td>1V to 4V - Sensor 1 1V to 4V - Sensor 2</td></tr> <tr><td>8</td><td>0V to 5V - Sensor 1 5V to 0V - Sensor 2</td></tr> <tr><td>9</td><td>0.5V to 4.5V - Sensor 1 4.5V to 0.5V - Sensor 2</td></tr> </table>	0	0V-5V	1	0.5V-4.5V	2	0.25V-4.75V	3	1V-4V	4	0V to 5V - Sensor 1 0V to 5V - Sensor 2	5	0.5V to 4.5V - Sensor 1 0.5V to 4.5V - Sensor 2	6	0.25V to 4.75V - Sensor 1 0.25V to 4.75V - Sensor 2	7	1V to 4V - Sensor 1 1V to 4V - Sensor 2	8	0V to 5V - Sensor 1 5V to 0V - Sensor 2	9	0.5V to 4.5V - Sensor 1 4.5V to 0.5V - Sensor 2	<table border="1"> <tr><td>10</td><td>0.25V to 4.75V - Sensor 1 4.75V to 0.25V - Sensor 2</td></tr> <tr><td>11</td><td>1V to 4V - Sensor 1 4V to 1V - Sensor 2</td></tr> <tr><td>0U</td><td>USB-Horizontal, mini B termination²</td></tr> <tr><td>2U</td><td>USB-Vertical cable exit³</td></tr> <tr><td>1J</td><td>Cursor Emulation</td></tr> <tr><td>0V</td><td>0V TO 5V (Voltage Regulator)⁴</td></tr> <tr><td>BV</td><td>±10V (Voltage Regulator)⁵</td></tr> <tr><td>2C</td><td>CAN bus J1939⁶</td></tr> <tr><td>3C</td><td>CANopen⁶</td></tr> <tr><td>4C</td><td>CANopen LSS⁶</td></tr> </table>	10	0.25V to 4.75V - Sensor 1 4.75V to 0.25V - Sensor 2	11	1V to 4V - Sensor 1 4V to 1V - Sensor 2	0U	USB-Horizontal, mini B termination ²	2U	USB-Vertical cable exit ³	1J	Cursor Emulation	0V	0V TO 5V (Voltage Regulator) ⁴	BV	±10V (Voltage Regulator) ⁵	2C	CAN bus J1939 ⁶	3C	CANopen ⁶	4C	CANopen LSS ⁶																											
0	0V-5V																																																																						
1	0.5V-4.5V																																																																						
2	0.25V-4.75V																																																																						
3	1V-4V																																																																						
4	0V to 5V - Sensor 1 0V to 5V - Sensor 2																																																																						
5	0.5V to 4.5V - Sensor 1 0.5V to 4.5V - Sensor 2																																																																						
6	0.25V to 4.75V - Sensor 1 0.25V to 4.75V - Sensor 2																																																																						
7	1V to 4V - Sensor 1 1V to 4V - Sensor 2																																																																						
8	0V to 5V - Sensor 1 5V to 0V - Sensor 2																																																																						
9	0.5V to 4.5V - Sensor 1 4.5V to 0.5V - Sensor 2																																																																						
10	0.25V to 4.75V - Sensor 1 4.75V to 0.25V - Sensor 2																																																																						
11	1V to 4V - Sensor 1 4V to 1V - Sensor 2																																																																						
0U	USB-Horizontal, mini B termination ²																																																																						
2U	USB-Vertical cable exit ³																																																																						
1J	Cursor Emulation																																																																						
0V	0V TO 5V (Voltage Regulator) ⁴																																																																						
BV	±10V (Voltage Regulator) ⁵																																																																						
2C	CAN bus J1939 ⁶																																																																						
3C	CANopen ⁶																																																																						
4C	CANopen LSS ⁶																																																																						

1 Output voltage is ratiometric to supply voltage.

2 Cable length is 6" ±1" fside of joystick to Male Type A USB connector.

3 Cable length is 84" ±1" from bottom of joystick to Male Type A USB connector.

4 Requires operating voltage $7V \geq 35V$.

5 Requires operating voltage $11V \geq 35V$.

6 Operating voltage: 7 - 35VDC.

7 L "locked" limiter plate is only recommended for handles with a rotational third / Z axis. Handles (33 - 56)

8 Optional mating wire harnesses may be selected for option options 0-11. Termination is included for output options 0U, 2U, 1J, 0V, BV, 2C, 3C, 4C.

9 R - restricts or locks the Z axis function on handles 33-56. This option prevents the handle from rotating.

HF series

Proportional multi-axis fingertip controllers •
non-contacting Hall effect technology

HANDLE 10

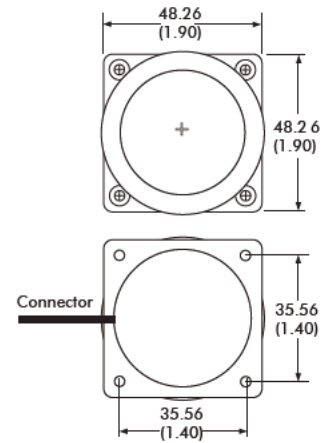
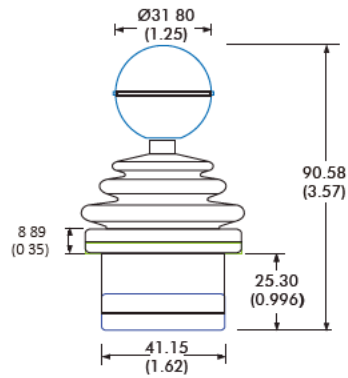

HANDLE 11

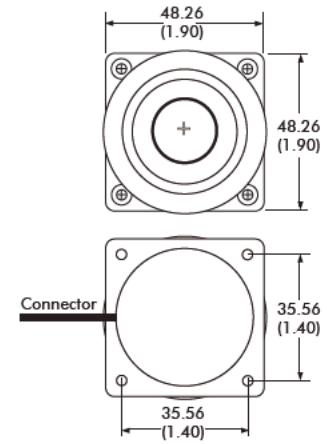
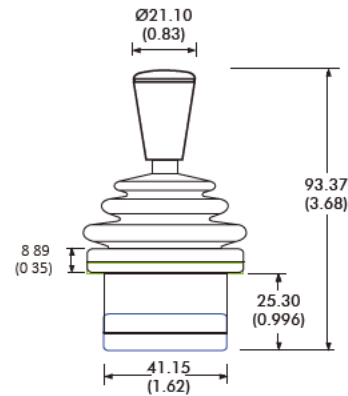

HANDLE 22

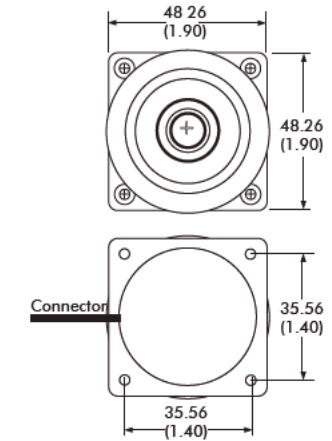
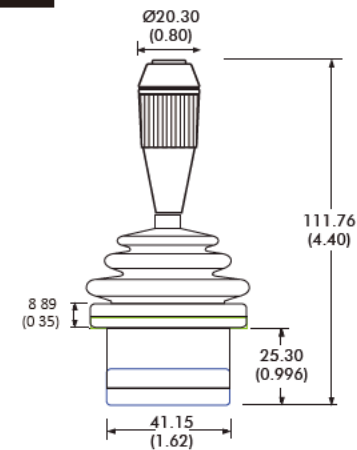

HANDLE 27

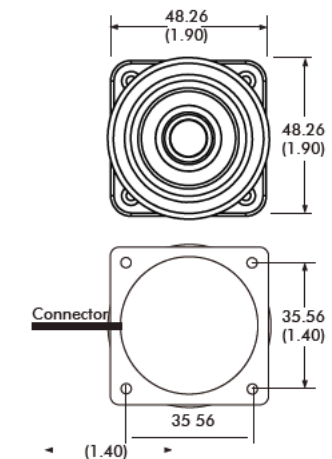
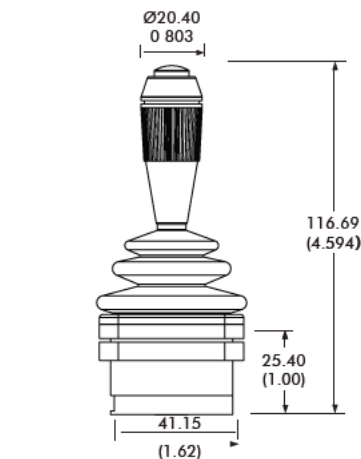

HF series

Proportional multi-axis fingertip controllers • non-contacting Hall effect technology

HANDLE 33

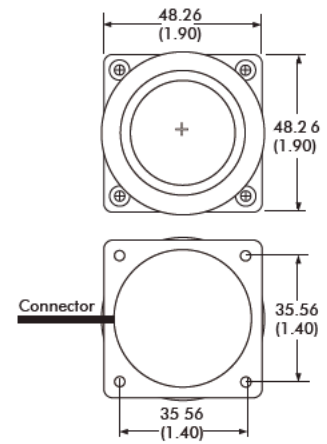
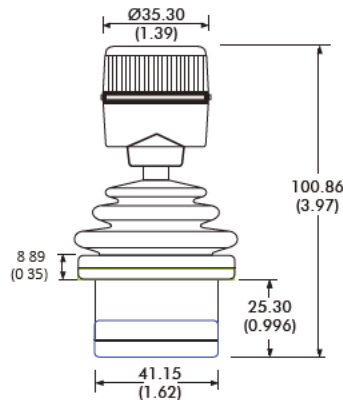

HANDLE 44

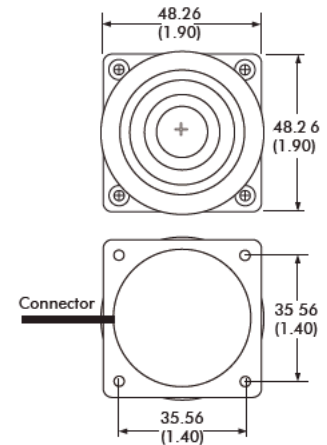
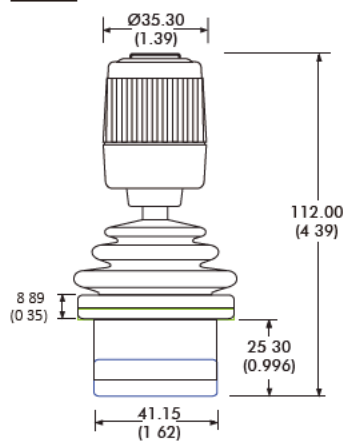

HANDLE 45

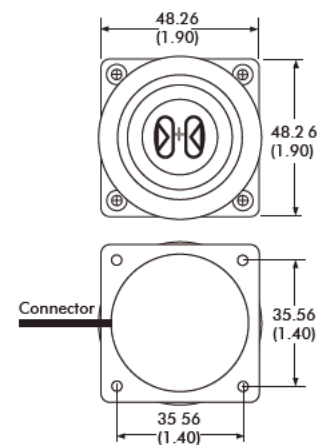
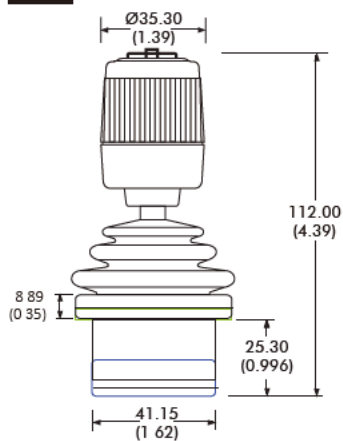

HANDLE 46

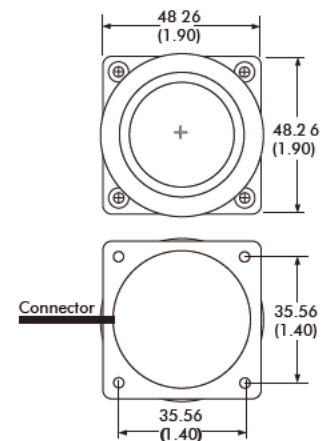
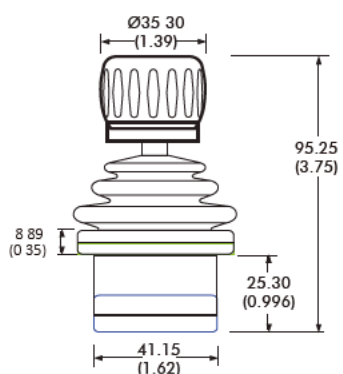

HF series

Proportional multi-axis fingertip controllers • non-contacting Hall effect technology

HANDLE 50

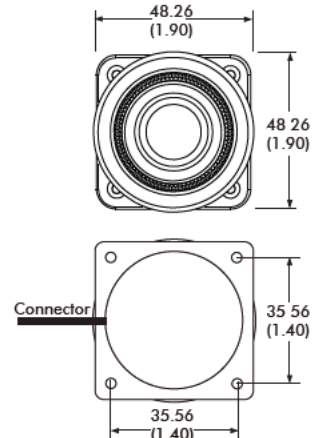
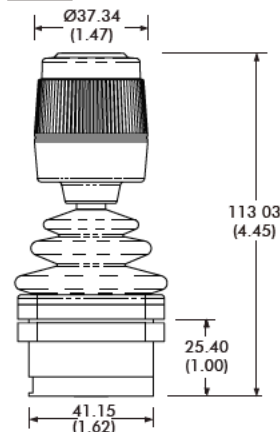

HANDLE 51

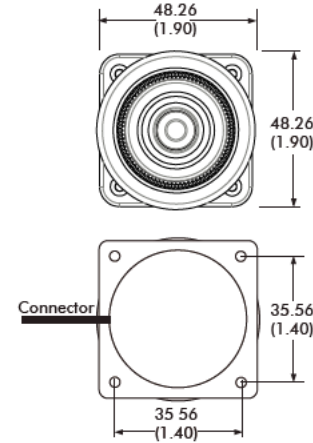
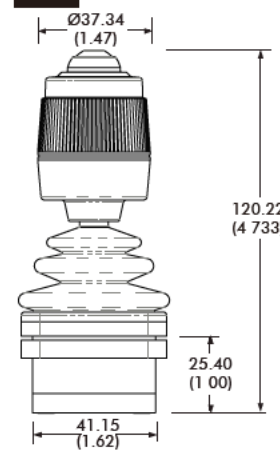

HANDLE 52

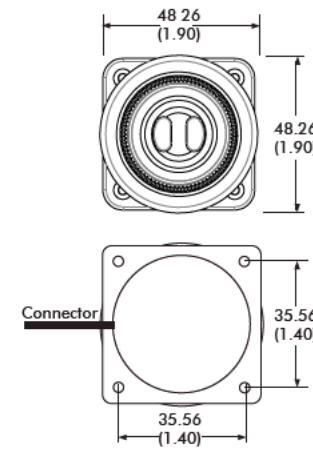
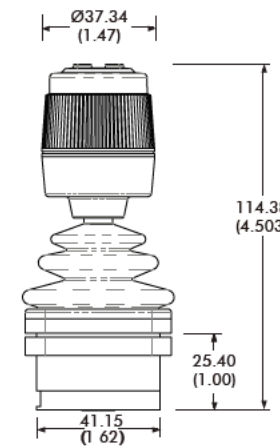

HANDLE 55

