

Specifications

Rating:	15A 250VAC
Contact Resistance:	25mΩ Max
Insulation Resistance:	100MΩ Min
Dielectric Strength:	2000VAC 1 minute
Operating Temperature:	-25°C to +75°C
Electrical Life:	100,000+ Cycles

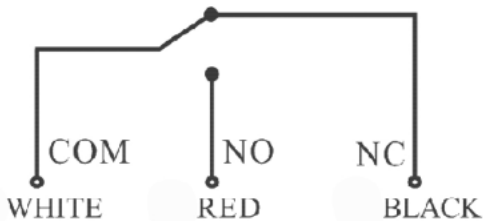
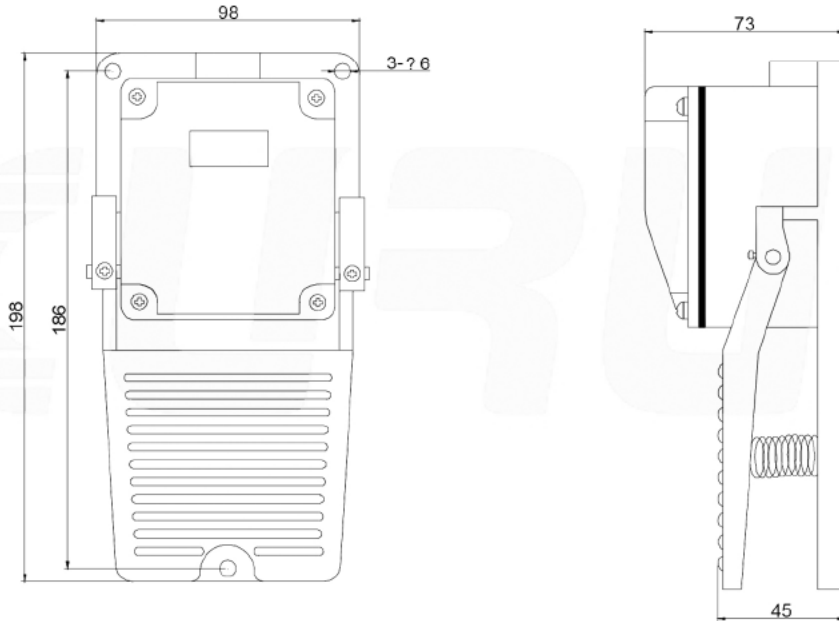

Description	Ref Code
Aluminium IP65 Foot Switch SPDT 15A 250VAC	482564