

Specifications

Rating:	5A 250VAC
Protection Level:	IP67
LED illumination:	12V
Housing Material:	Stainless Steel
Contacts:	2NO/2NC
Contact Resistance:	50mΩ Max
Insulation Resistance:	1000MΩ Min
Dielectric Strength:	2000VAC 1 minute
Operating Temperature:	-25°C to +85°C

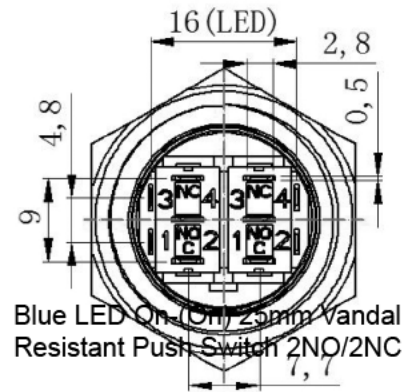

Blue LED On-Off 25mm Vandal Resistant Push Switch 2NO/2NC

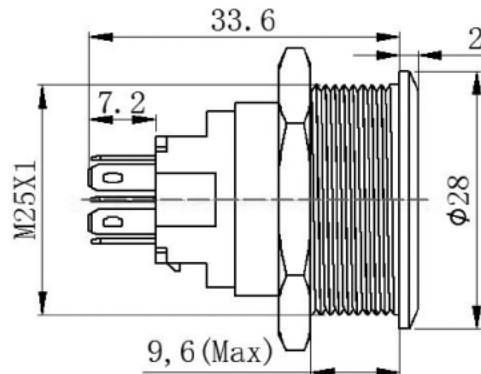
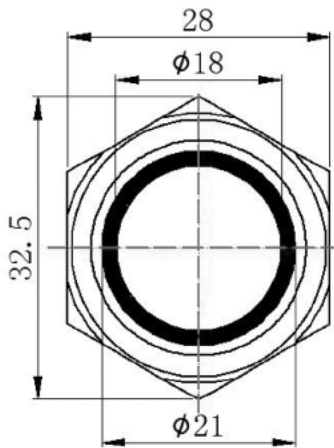
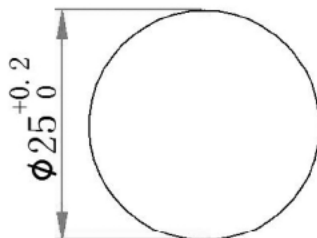
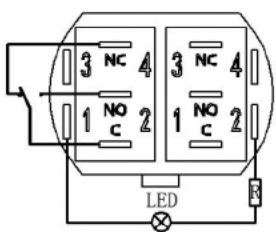

Description	Ref Code
	483348