

ø22 CW Series
Flush Silhouette Touchless Switches
CW1H/CW4H



Touchless Switches

For indoor and outdoor use
Suitable for hygiene protection



Touchless switches suitable for both indoor and outdoor use



Degree of protection: **IP65/67** suitable for outdoor use

UL Type 4X (Outdoor) approved.

Features weather-resistant material.



Output and standby status feedback by LED illumination in **two colors** that can be externally controlled.



Illumination
Color: Green



Illumination
Color: Red

NEW **Blue / Pure White** color variation (made-to-order product)

Color combination that can be recognized by majority of people regardless of individual differences in color vision.





The need for touchless switches to minimize the spread of viruses is increasing. The risk is especially high when an unspecified number of people touch the same surface. Touchless switches can be used in a wide range of applications to reduce the risk of contamination.



Standard model (diffuse reflective)

Near-infrared reflectance. Hand detection distance adjustable from **approx. 70 to 270mm**. (*1)
Suitable for applications that require a long range detection.

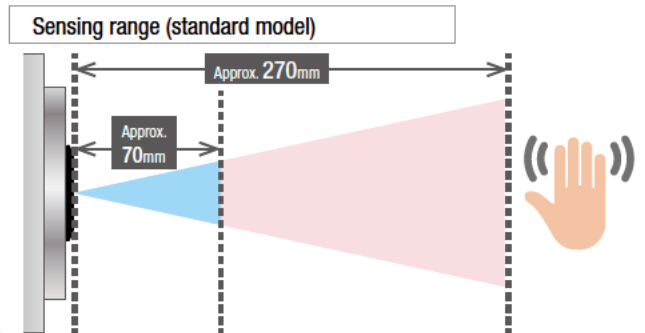

*1) Sensing object: Human hand. See page 6 for "Detection distance range by object" for objects other than hands. Sensitivity control available for standard models only

Available soon

Short range detection model (convergent reflective)

Emits and receives light at an angle. Detects objects only within a specific distance range
Sensing range **approx. 5 to 30mm**.
Suitable for applications that require only short range detection. Avoids long range detection.

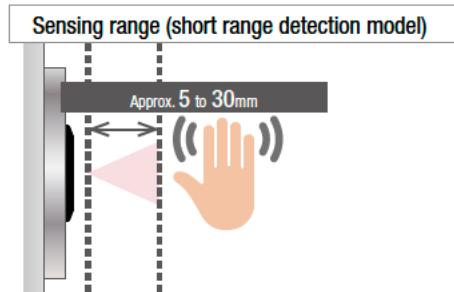

Models with **time delay** available to prevent malfunction.

*PNP models only

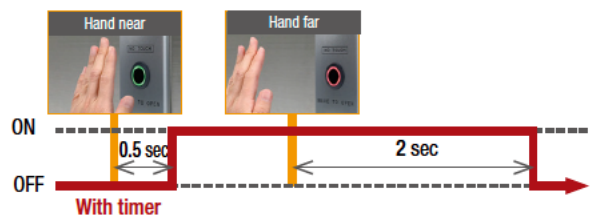

Public areas where unspecified number of people touch the same surface

Public facilities



Elevators



Reduces the risk of viruses and bacteria spreading in applications with frequent access.

Locations requiring weather resistance and durability

Parking garages



Parking ticket machines



For use in a variety of applications, both indoors and outdoors.

Locations requiring hygiene measures

Air shower



Food machinery



As direct contact is not required, touchless switches can be used in applications that minimize the spread of viruses.

Frequently operated equipment

Machine equipment



Picking



Reduces operation fatigue when operating buttons and improves switch life.

ø22 CW Series Flush Silhouette Touchless Switches CW1H/CW4H

Touchless switches reduce risk in public and shared spaces.

- Suitable for indoor and outdoor use
- Adjustable detection distance
- Two-color LED illumination enables identification of output and standby



• See website for details on approvals and standards.



General Specifications

Operating temperature	When in use: -25 to +55°C When storing: -35 to +70°C (no freezing)
Operating humidity	When in use: 35 to 95%RH When storing: 35 to 95%RH (no condensation)
Detection method	Diffuse reflection method
Adjustable range of maximum detection distance	120 to 350mm (White drawing paper 200 x 200mm square) Approx. 70 to 270mm if the object is a hand (reference value)
Light source	Infrared LED
Rated voltage	12 to 24V DC Allowable ripple rate ±10%
Current draw	40mA maximum (main circuit) 20mA maximum (illumination part)

Control output	Non-contact (photoMOS relay) output Load power supply voltage: 24V DC± 10% max. (Load current: 100mA max.) Voltage drop: 1.0V max. (Load current: 100mA max.)	
Protection circuit	Power supply reverse connection protection	
Response time	Turn-on ≤ 2.5ms, turn-off ≤ 1ms	
Delay time	On-delay	0.5 ± 0.1s (with timer model)
	Off-delay	2.0 ± 0.1s (with timer model)
Materials	Bezel / Main body	Black plastic :PA66 Metal: Aluminum alloy
	Lens	PMMA
	Degree of protection	IP65/67, UL Type 4X (OUTDOOR USE) *Front of the panel
Weight	CW1H: 15g CW4H: 20g	

CW1H/CW4H

Package Quantity: 1

Name	Shape	Sensing method	Bezel specification	Illumination color (LIGHT1 / LIGHT2)	Illumination control method	Timer	Part No.
CW Series Touchless Switches		Diffuse-reflective	Black plastic	Green / Red	PNP	Without timer	CW1H-DM1NGR-C
							NPN
					PNP	With timer	
				Blue / Pure white		PNP	Without timer
					NPN		
						Metal	Green / Red
	NPN		CW4H-DM1NGR-C-N				
			PNP	With timer	CW4H-DM1TGR-C		
	Blue / Pure white			PNP	Without timer		CW4H-DM1NSPW-C
			NPN				CW4H-DM1NSPW-C-N

• Dedicated cable for external connection is not supplied. (One each of locking ring and rubber washer is supplied)

Accessories

Name	Shape	Description	Part No.	Ordering No.	Package Quantity	Remarks
Cable for external connection		AWG22	CW9Z-CN	CW9Z-CN200	1	
				CW9Z-CN500		
				CW9Z-CN1M (*1)		
Locking ring		Polyamide Resin (black)	CW9Z-LN	CW9Z-LNPN05	1 (5 pcs)	—
Rubber washer		Nitrile rubber	CW9Z-WM	CW9Z-WMPN10	1 (10 pcs)	For waterproofing between the mounting panel and the main body.
Locking ring wrench		Metal (brass)	MW9Z-T1	MW9Z-T1	1	<ul style="list-style-type: none"> • Used to attach the unit to the panel. • Weight: Approx. 150g

*1) Made-to-order product

*2) Contact SOCOJE for lengths other than 200mm, 500mm, and 1000mm.

Nameplates

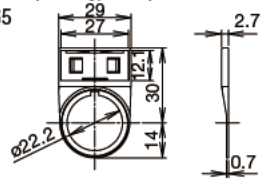
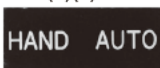
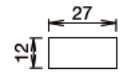
Name / Shape	Description	Part No.	Ordering No.	Package Quantity	Remarks
Nameplate CWAM 	Plastic (Black)	CWAM	CWAM	1	<ul style="list-style-type: none"> Marking plate HWNP (sold separately) is required. Degree of protection: IP65 Attach the nameplate with the switch actuator rubber washer attached. 
Marking plate HWNP (*1) (*2) 	Aluminum (Black)	HWNP-□	HWNP-□	1	<ul style="list-style-type: none"> White letters on black background Engraving area: W25 H7. 
Photo: HWNP-35			HWNP-□PN10	1 (10 pcs)	

*1) Available in units of 1 piece, but standard prices vary.
 *2) Specify the legend code below in place of □ in the part number.

Legend for marking plate

Code	Legend	Code	Legend
0	Blank	4	STOP
1	ON	31	OFF-ON
2	OFF	35	HAND-AUTO
3	START	53	HAND-OFF-AUTO

Dimensions

All dimensions in mm.

Main body

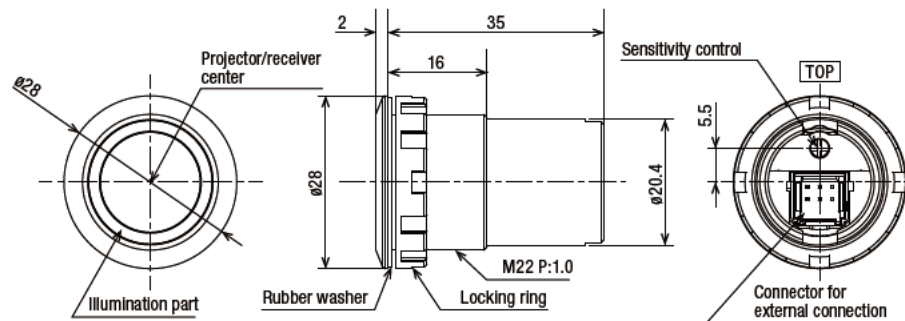

Mounting Hole Layout

All dimensions in mm.

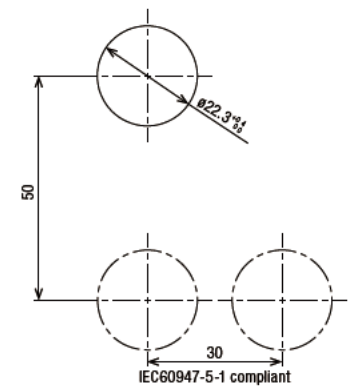

- Determine mounting centers to ensure easy operation.

Characteristics

Detection area

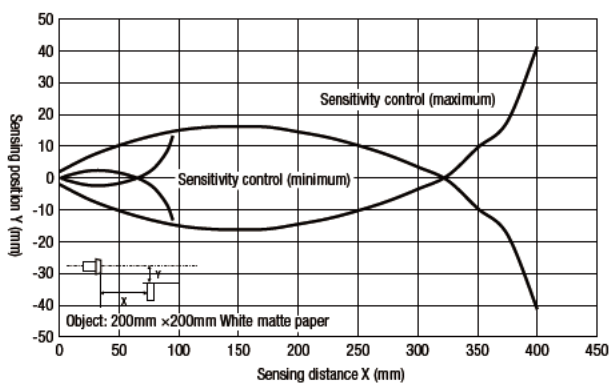

Detection distance range by object

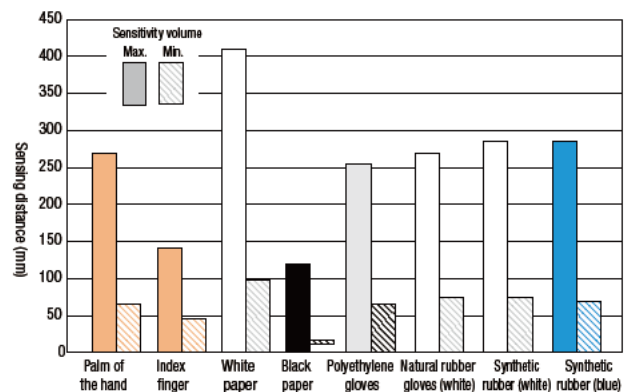

- Detection distance measured using the actual object (using gloves).
- 200x200mm white and black paper used.

Safety Precautions

- Turn off the power to the product before starting installation, removal, wiring, maintenance, or inspection. Failure to turn power off may cause electrical shock or fire.

Instructions

- Since the power reset time is 100ms, start use after 100ms when power is turned on.
- If the load and this product are connected to separate power supplies, be sure to turn on the power to this product first.
- Do not install or use the product in the following places as it may cause malfunction or damage.
 - 1) Near induction equipment or heat sources
 - 2) Locations subject to high vibration or shock
 - 3) Dusty places
 - 4) Locations subject to harmful gases
 - 5) Locations directly exposed to water, oil, chemicals, etc.
 - 6) Locations where icing may occur
- Install the sensor so that light from sunlight or fluorescent lamps does not directly reach the detection surface.
- Mirror surfaces with high reflectivity and reflectors may cause extremely long detection distances at unexpected detection ranges.
- Water droplets, dirt, etc., on the sensor surface may affect the detection performance, so wipe off with a soft cloth before use.
- Since PMMA is used as the material for the optical part, do not use organic solvents such as ammonia, sodium hydroxide, alcohol, or thinner.

Caution

- Do not use a power supply outside the rated operating voltage range or AC power. Otherwise explosion or burning may occur.
- Avoid continuous lighting of two LED illumination colors simultaneously, as it may cause damage to the product.

Installation

- Tighten the locking ring to the recommended tightening torque (1.2 N·m) with the optional locking ring wrench (MW9Z-T1). Install on a flat surface. Mounting on a non-flat surface may damage the product or impair its waterproof performance

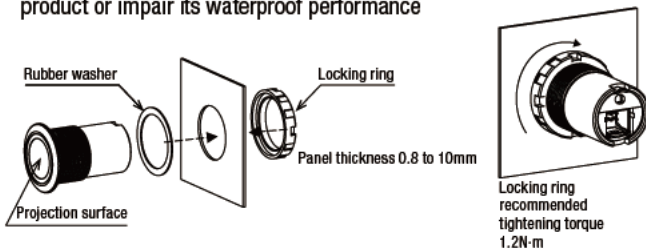

- When multiple units are installed adjacent to each other, take into consideration the mounting centers of the switches and the location of objects to be detected.

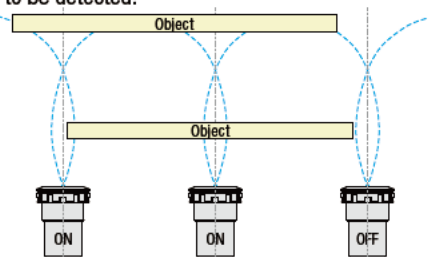

Wiring

- Turn off the power to the product before starting wiring.
- Wiring errors may cause damage to the internal circuit. Be sure to refer to the connection diagram.
- Use within the range of the rated operating voltage.
- When using a switching power supply for power, be sure to ground the FG terminal.
- Avoid parallel wiring using piping or ducts with high-voltage lines or power lines (especially inverter power lines), as malfunction or damage may be caused due to inductive noise.
- When long wiring is used or when power sources or electromagnetic equipment may affect the product, use individual wiring.
- The illumination unit may light dimly due to inductive noise, etc. In this case, take countermeasures by connecting each terminals LIGHT1, LIGHT2, and PNP illumination control type to 0V, and by connecting the below shunt resistor between +V for NPN illumination control type. (See diagram below)

Shunt resistor R

Resistance value	Rated current
20kΩ	0.25W minimum

Connection diagram

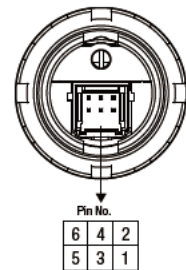
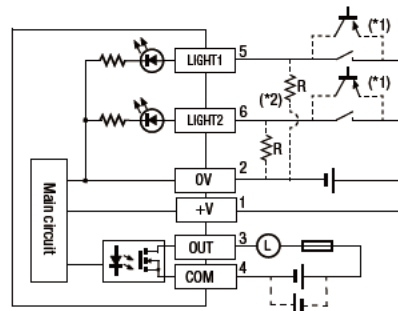

- R : Shunt resistor
- L : Load
- Overcurrent protection element such as a fuse (100mA max.)

Pin No.	Terminal no.
1	+V
2	0V
3	OUT
4	COM
5	LIGHT1
6	LIGHT2

- *1) NPN cannot be connected
- *2) Connect only when dim lighting countermeasures are required
- *3) PNP connection not recommended

Compatible connectors for external connection

Parts	Part No.	Manufacturer
Crimp socket	DF51K-6DS-2C (800)	Hirose Electric Co. Ltd.
Socket for crimping terminal	DF51K-22SCF (800) or DF51K-22SC (800)	

- Be sure to read the instructions carefully before performing installation, wiring, or maintenance work.

Ordering Terms and Conditions

Thank you for using SOCOJE Products.

By purchasing products listed in our catalogs, datasheets, and the like (hereinafter referred to as "Catalogs") you agree to be bound by these terms and conditions. Please read and agree to the terms and conditions before placing your order

1. Notes on contents of Catalogs

- (1) Rated values, performance values, and specification values of SOCOJE products listed in this Catalog are values acquired under respective conditions in independent testing, and do not guarantee values gained in combined conditions.
Also, durability varies depending on the usage environment and usage conditions.
- (2) Reference data and reference values listed in Catalogs are for reference purposes only, and do not guarantee that the product will always operate appropriately in that range.
- (3) The specifications / appearance and accessories of SOCOJE products listed in Catalogs are subject to change or termination of sales without notice, for improvement or other reasons.
- (4) The content of Catalogs is subject to change without notice.

2. Note on applications

- (1) If using SOCOJE products in combination with other products, confirm the applicable laws / regulations and standards.
Also, confirm that SOCOJE products are compatible with your systems, machines, devices, and the like by using under the actual conditions.
SOCOJE shall bear no liability whatsoever regarding the compatibility with SOCOJE products.
- (2) The usage examples and application examples listed in Catalogs are for reference purposes only. Therefore, when introducing a product, confirm the performance and safety of the instruments, devices, and the like before use. Furthermore, regarding these examples, SOCOJE does not grant license to use SOCOJE products to you, and SOCOJE offers no warranties regarding the ownership of intellectual property rights or non-infringement upon the intellectual property rights of third parties.
- (3) When using SOCOJE products, be cautious when implementing the following.
 - i. Use of SOCOJE products with sufficient allowance for rating and performance
 - ii. Safety design, including redundant design and malfunction prevention design that prevents other danger and damage even in the event that an SOCOJE product fails
 - iii. Wiring and installation that ensures the SOCOJE product used in your system, machine, device, or the like can perform and function according to its specifications
- (4) Continuing to use an SOCOJE product even after the performance has deteriorated can result in abnormal heat, smoke, fires, and the like due to insulation deterioration or the like. Perform periodic maintenance for SOCOJE products and the systems, machines, devices, and the like in which they are used.
- (5) SOCOJE products are developed and manufactured as general-purpose products for general industrial products. They are not intended for use in the following applications, and in the event that you use an SOCOJE product for these applications, unless otherwise agreed upon between you and SOCOJE shall provide no guarantees whatsoever regarding SOCOJE products.
 - i. Use in applications that require a high degree of safety, including nuclear power control equipment, transportation equipment (railroads / airplanes / ships / vehicles / vehicle instruments, etc.), equipment for use in outer space, elevating equipment, medical instruments, safety devices, or any other equipment, instruments, or the like that could endanger life or human health
 - ii. Use in applications that require a high degree of reliability, such as provision systems for gas / waterworks / electricity, etc., systems that operate continuously for 24 hours, and settlement systems
 - iii. Use in applications where the product may be handled or used deviating from the specifications or conditions / environment listed in the Catalogs, such as equipment used outdoors or applications in environments subject to chemical pollution or electromagnetic interference. If you would like to use SOCOJE products in the above applications, be sure to consult with an SOCOJE sales representative.

3. Inspections

We ask that you implement inspections for SOCOJE products you purchase without delay, as well as thoroughly keep in mind management/maintenance regarding handling of the product before and during the inspection.

4. Warranty

- (1) Warranty period
The warranty period for SOCOJE products shall be one (1) year after purchase or delivery to the specified location. However, this shall not apply in cases where there is a different specification in the Catalogs or there is another agreement in place between you and SOCOJE.
- (2) Warranty scope
Should a failure occur in an SOCOJE product during the above warranty period for reasons attributable to SOCOJE, then SOCOJE shall replace or repair that product, free of charge, at the purchase location / delivery location of the product, or an SOCOJE service base. However, failures caused by the following reasons shall be deemed outside the scope of this warranty.
 - i. The product was handled or used deviating from the conditions / environment listed in the Catalogs
 - ii. The failure was caused by reasons other than an SOCOJE product
 - iii. Modification or repair was performed by a party other than IDEC
 - iv. The failure was caused by a software program of a party other than IDEC
 - v. The product was used outside of its original purpose
 - vi. Replacement of maintenance parts, installation of accessories, or the like was not performed properly in accordance with the user's manual and Catalogs
 - vii. The failure could not have been predicted with the scientific and technical standards at the time when the product was shipped from IDEC
 - viii. The failure was due to other causes not attributable to SOCOJE (including cases of force majeure such as natural disasters and other disasters)

Furthermore, the warranty described here refers to a warranty on the SOCOJE product as a unit, and damages induced by the failure of an SOCOJE product are excluded from this warranty.

5. Limitation of liability

The warranty listed in this Agreement is the full and complete warranty for SOCOJE products, and SOCOJE shall bear no liability whatsoever regarding special damages, indirect damages, incidental damages, or passive damages that occurred due to an SOCOJE product.

6. Service scope

The prices of SOCOJE products do not include the cost of services, such as dispatching technicians. Therefore, separate fees are required in the following cases.

- (1) Instructions for installation / adjustment and accompaniment at test operation (including creating application software and testing operation, etc.)
- (2) Maintenance inspections, adjustments, and repairs
- (3) Technical instructions and technical training
- (4) Product tests or inspections specified by you

The above content assumes transactions and usage within your region. Please consult with an SOCOJE sales representative regarding transactions and usage outside of your region. Also, SOCOJE provides no guarantees whatsoever regarding SOCOJE products sold outside your region.

