

HG series

Hand grip Hall effect joysticks



The HG Series joystick is a rugged Hall effect controller designed for use in high operating force, hand-operated applications requiring reliable positioning control. Available with several high-function handles and in single, dual or triple axes configurations, HG Series joysticks are custom configured to meet the exacting requirements of harsh applications. Typical applications include military vehicles, refuse handling trucks, as well as fire and off-highway vehicles.

KEY FEATURES





- Rugged, hand operation
- Hall effect sensing
- Sealed up to IP68
- 10 million life cycles
- Redundant output available
- Analog, CANbus, USB and custom outputs available



HG series

Hand grip Hall effect joysticks

OPTION SELECTION

HG				
SERIES	TOP BUTTONS	LIMITER PLATE	OUTPUT OPTIONS	
	<p>0 None</p> <p>1 One</p> <p>2 Two</p> <p>M Multifunction*</p> <p>* - Multifunction handle will be specified in an extension</p>	<p>S Square </p> <p>R Round </p> <p>X Slotted </p> <p>Y Slotted </p> <p>P Plus </p>	<p>0 0V to 5V (Rail to Rail)</p> <p>1 0.5V to 4.5V</p> <p>2 0.25V to 4.75V</p> <p>3 1V to 4V</p> <p>4 0V to 5V - Sensor 1 0V to 5V - Sensor 2</p> <p>5 0.5V to 4.5V - Sensor 1 0.5V to 4.5V - Sensor 2</p> <p>6 0.25V to 4.75V - Sensor 1 0.25V to 4.75V - Sensor 2</p> <p>7 1V to 4V - Sensor 1 1V to 4V - Sensor 2</p> <p>8 0V to 5V - Sensor 1 5V to 0V - Sensor 2</p> <p>9 0.5V to 4.5V - Sensor 1 4.5V to 0.5V - Sensor 2</p> <p>10 0.25V to 4.75V - Sensor 1 4.75V to 0.25V - Sensor 2</p> <p>11 1V to 4V - Sensor 1 4V to 1V - Sensor 2</p> <p>0-U USB</p> <p>0-D Discrete</p> <p>1-J Cursor Emulation</p> <p>2-C CANbus</p>	
HANDLE¹	SIDE BUTTONS	SPRING TENSION⁸		ADDITIONAL OPTIONS
<p>10 Ball Tip (2 axes)</p> <p>21 Stock Grip (2 axes)</p> <p>22 Short Stock Grip (2 axes)</p> <p>33 Multifunction Square (2 axes)</p> <p>43 Multifunction Square (3 axes)</p> <p>34 Multifunction Oval (2 axes)</p> <p>44 Multifunction Oval (3 axes)</p> <p>2X No Handle</p> <p>2Z Custom Handle</p>	<p>0 None</p> <p>U One - Upper Position</p> <p>L One - Lower Position</p> <p>T Two</p> <p>D Deadman</p> <p>I Index Trigger</p>	<p>00 Standard</p> <p>10 Light*</p> <p>20 Heavy</p> <p>* - Not recommended for use with multifunction handles.</p>		<p>V Voltage Regulator</p> <p>D Dual Decode ⁹</p> <p>DC Center Detect</p> <p>AD Analog Deadband</p> <p>P Proximity Sensor</p> <p>E Environmental Sealing*</p>

NOTES:

1. Refer to next page for information on standard configurations for joysticks with Stock Grip, Short Stock Grip, and Multifunction handles.
2. Stock Grip handles can have either a Deadman or a Proximity Switch.
3. Multifunction handles can have either an Index Trigger or a Proximity Switch.
4. When ordering the multifunction handle, specify Square or Oval.
5. Multifunction handle orders should be accompanied by drawing of button/component placement.
6. Multifunction handle requires Drop-in mounting.
7. Option 2X (no handle) and Option 2Z (custom handle) may require discussion with Technical Support.
8. X/Y axes spring tension. Contact Technical Support for information on best possible spring for your chosen configuration.
9. Dual Decode cannot be used with CANbus, USB, or Voltage Regulator.



*Environmental sealing level available up to IP68. Dependent upon handle configuration.



Mounting accessories. Standard hardware includes: 1 gasket, 4 nuts (1/4-20), 4 washers (1/4), 4 screws (1/4-20x1 1/4)

HG series

Hand grip Hall effect joysticks

STANDARD CONFIGURATIONS

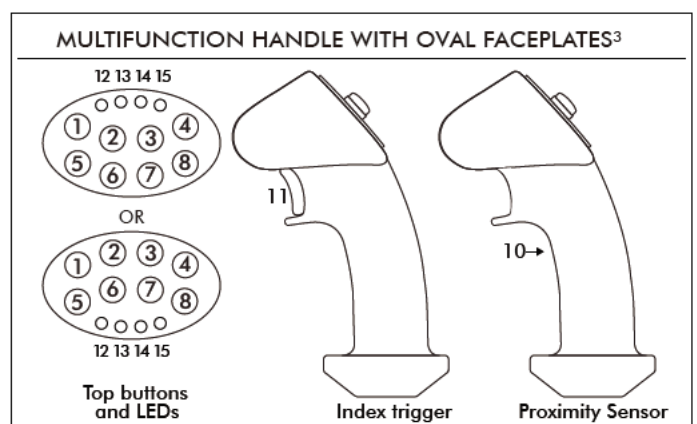
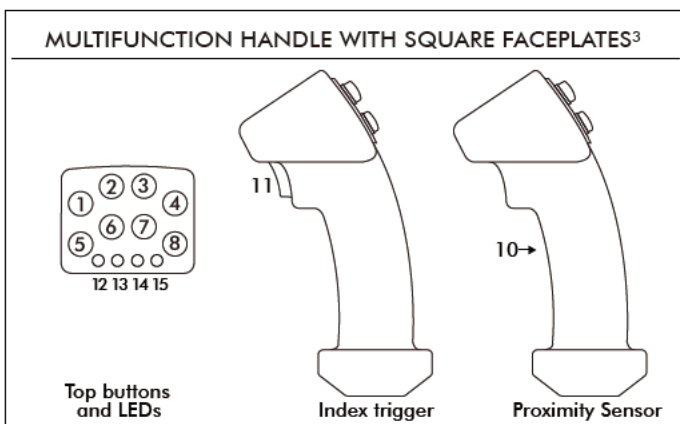
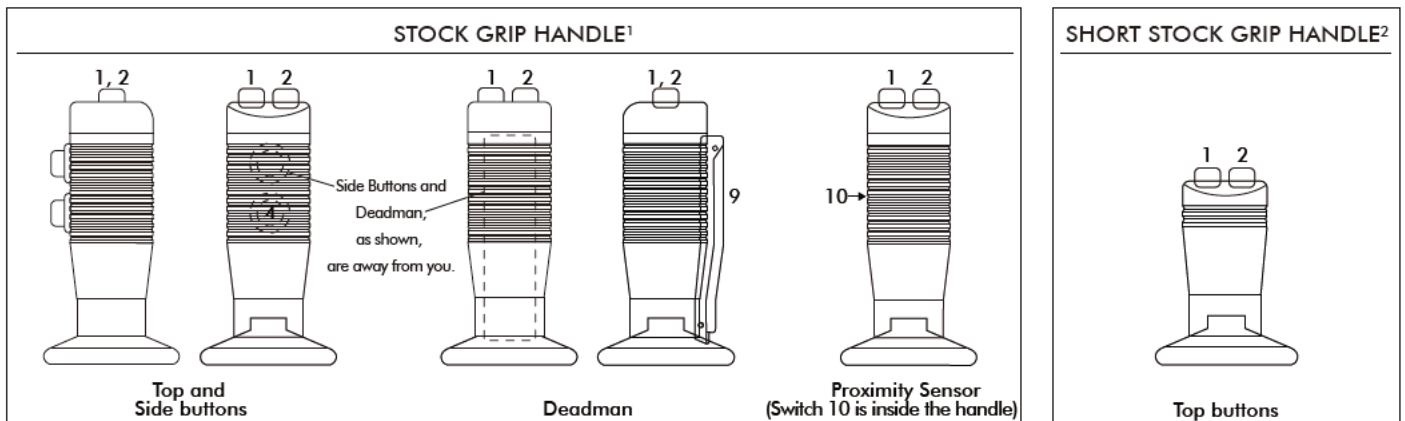

DEFAULT WIRE COLOR CODE*		
COLOR	FUNCTION	AWG
RED	Vcc or Vdd	28
BLACK	Ground	
BLUE	X Axis	
YELLOW	Y Axis	
GREEN	Z Axis	
WHITE	Switch Common (optional)	22
ORANGE	Switch 1 (optional)	
VIOLET	Switch 2 (optional)	
GRAY	Switch 3 (optional)	
BROWN	Switch 4 (optional)	
PINK	Switch 5 (optional)	
BLUE/WHITE	Switch 6 (optional)	
YELLOW/BLACK	Switch 7 (optional)	
GREEN/BLACK	Switch 8 (optional)	
VIOLET/WHITE	Deadman - Switch 9 (optional)	
YELLOW/WHITE	Proximity Sensor - Switch 10 (optional)	
RED/WHITE	Index Trigger - Switch 11 (optional)	
LIGHT GREEN	LED - 12 (optional)	
LIGHT ORANGE	LED - 13 (optional)	
GRAY/WHITE	LED - 14 (optional)	
BLACK/WHITE	LED - 15 (optional)	



NOTES: * - Starting from the strain relief, the cable is 406mm (16in) long, 6.40mm (0.25in) stripped with plug, covered with an expandable cable sleeve.

- The maximum possible configuration for the Stock Grip handle is up to 2 Top Buttons and 2 Side Buttons. A handle with a Deadman or a Proximity Sensor can have 2 Top Buttons, but no Side Buttons.
- The maximum possible configuration for the Short Stock Grip handle is up to 2 Top Buttons. It is not possible with Deadman, Index Trigger, Proximity Switch, or Side Buttons.
- A Multifunction handle can have a maximum of 8 Top Buttons and 4 LEDs on the faceplate, and an Index Trigger or a Proximity Sensor.
- For non-standard configurations contact Technical Support. We can customize the faceplate according to your exact needs. For faceplate examples, see next page.
- If unspecified, the pushbuttons will have snap action momentary switches with red button caps.
- Switches will always be wired according to the position number on the handle and the Default Wire Color Code.

Note: The company reserves the right to change specifications without notice.

HG series

Hand grip Hall effect joysticks

FACEPLATE EXAMPLES

OVAL



1



2



3



4



5



6



7



8



9

SQUARE



10



11



12



13



14



15



16



17

HG series

Hand grip Hall effect joysticks

SPECIFICATIONS

MECHANICAL (FOR X AND Y AXES)

Break Out Force	-	7.7N (1.70lbf)
Operating Force	-	14.0N (3.10lbf)
Maximum Applied Force	-	1000.0N (225.00lbf)
Mechanical Angle of Movement	-	38°
Expected Life	-	10 million cycles
Lever Action (Centering)	-	Spring centering
Material	-	Glass reinforced nylon

MECHANICAL (FOR Z AXIS)

Break Out Torque	-	0.6N·m (5.31lbf-in)
Operating Torque	-	1.1N·m (9.74lbf-in)
Maximum Allowable Torque	-	24.5N·m (216.84lbf-in)
Hand Mechanical Angle	-	42°
Expected Life	-	10 million cycles

ENVIRONMENTAL

Operating Temperature	-	-25°C to 70°C (-13°F to 158°F)
Storage Temperature	-	-40°C to 70°C (-40°F to 158°F)
Sealing	-	IP65 to IP68 ¹
EMC Immunity Level (V/M)	-	IEC 61000-4-8:2009
EMC Emissions Level	-	IEC 61000-4-3:2006
ESD	-	IEC 61000-4-2:2008

ELECTRICAL

Sensor	-	Hall effect
Resolution	-	Infinite
Supply Voltage Operating	-	5.00VDC
Reverse Polarity Max	-	-14.5VDC
Overvoltage Max	-	18VDC
Output Voltage	-	0.34V - 4.65V
Output Impedance	-	6Ω
Current Consumption Max	-	10mA max per axis
Return to Center Voltage (No Load)	-	±200mV

STANDARD SWITCH CHARACTERISTICS/RATINGS

Electrical Resistive Load:	-	5A
Electrical Inductive Load:	-	3A
DWV:	-	1050Vrms
Low Level:	-	10mA @ 30mV
Electrical Life:	-	25,000 cycles 5A @ 28VDC resistive snap-action
Mechanical Life:	-	1 million cycles
Environmental Seal:	-	IP67
Action:	-	Momentary, snap-action
Operating Force:	-	7.5N±2.0N (1.69lbf±0.45lbf)
Total Travel:	-	0.080 inches max
Over Travel:	-	0.010 inches min

CANbus OUTPUT VERSION

Supply Voltage Range	-	6V to 40V
CANbus Version	-	J1939

NOTES:

- All values are nominal
- Exact specifications may be subject to configuration.
Contact Technical Support for the performance of your specific configuration.
- ¹ Excludes some handle options.

HG series

Hand grip Hall effect joysticks

DIMENSIONAL DRAWINGS

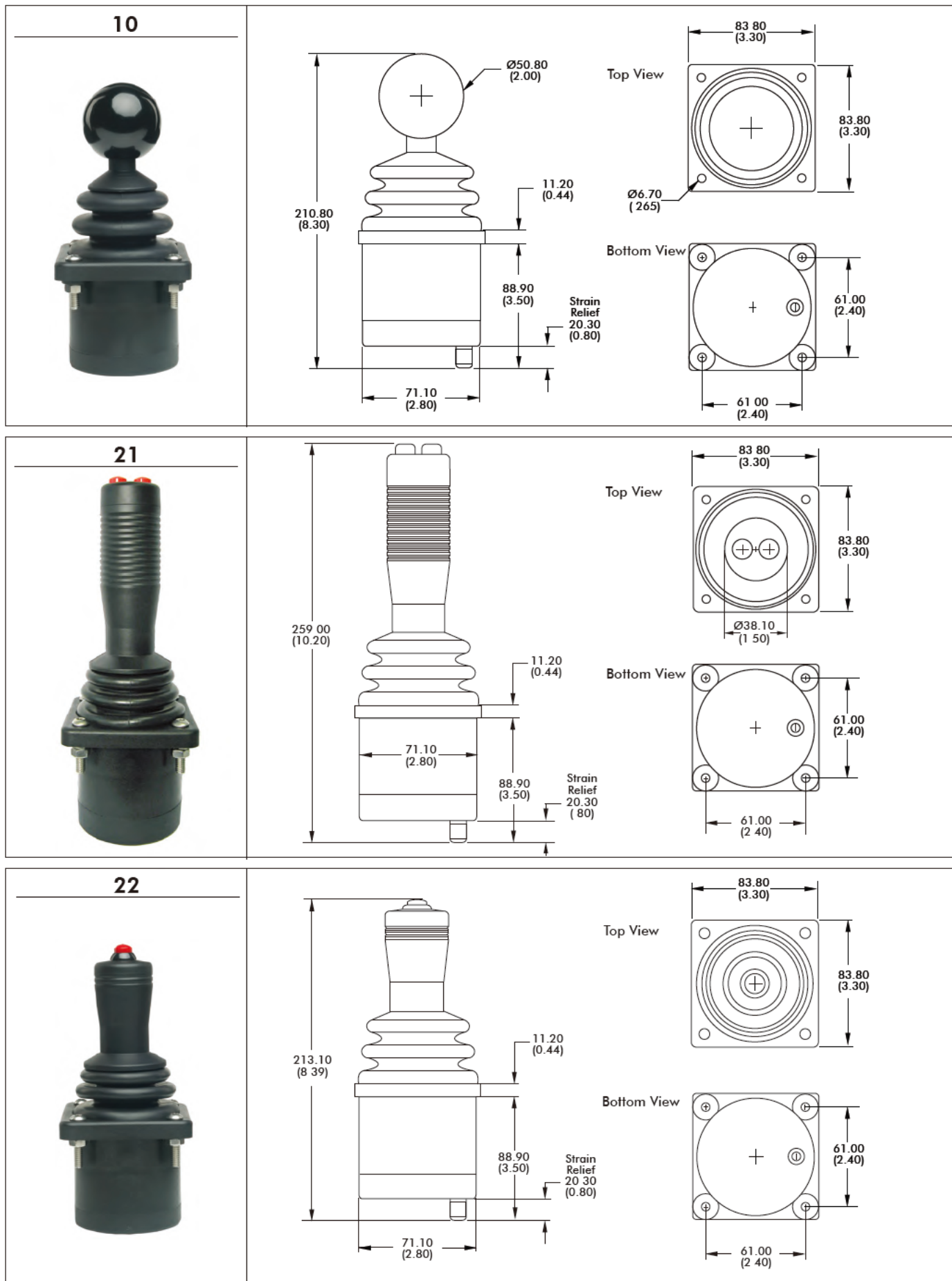

Note: The company reserves the right to change specifications without notice.

HG series

Hand grip Hall effect joysticks

DIMENSIONAL DRAWINGS - continued

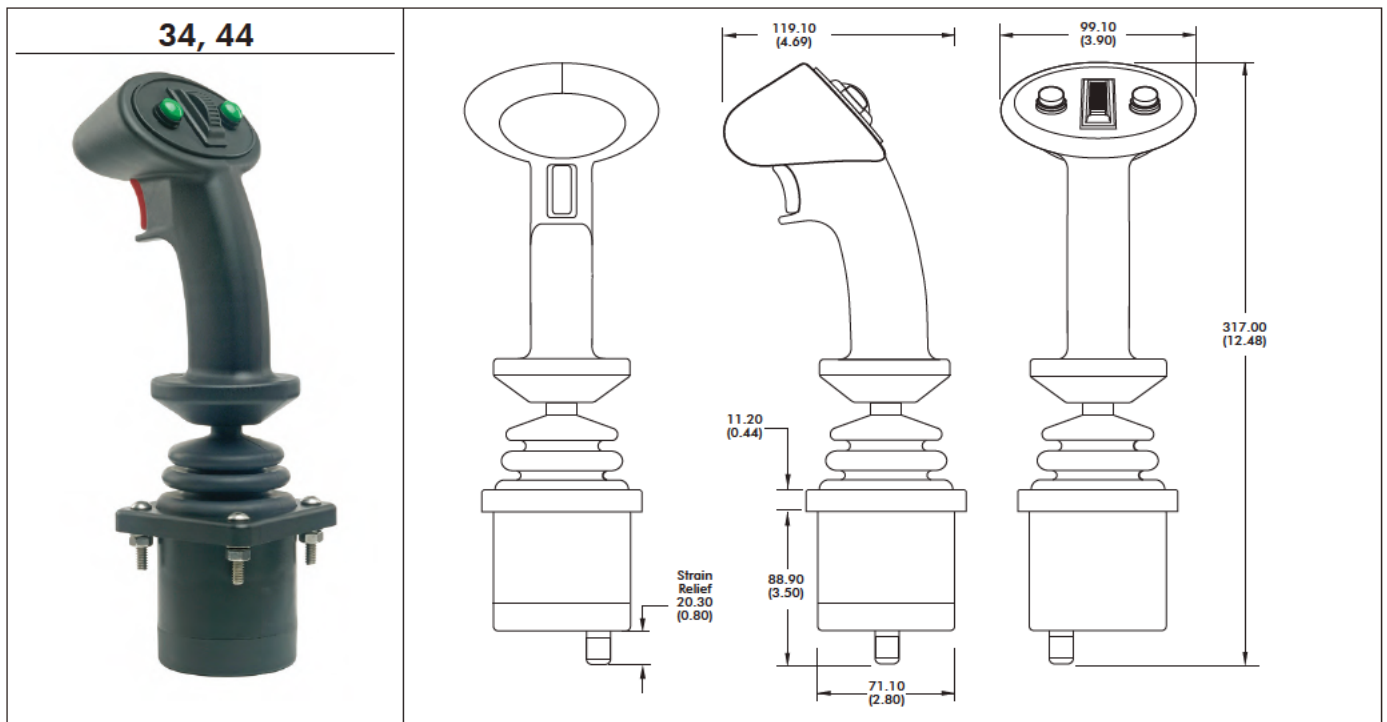
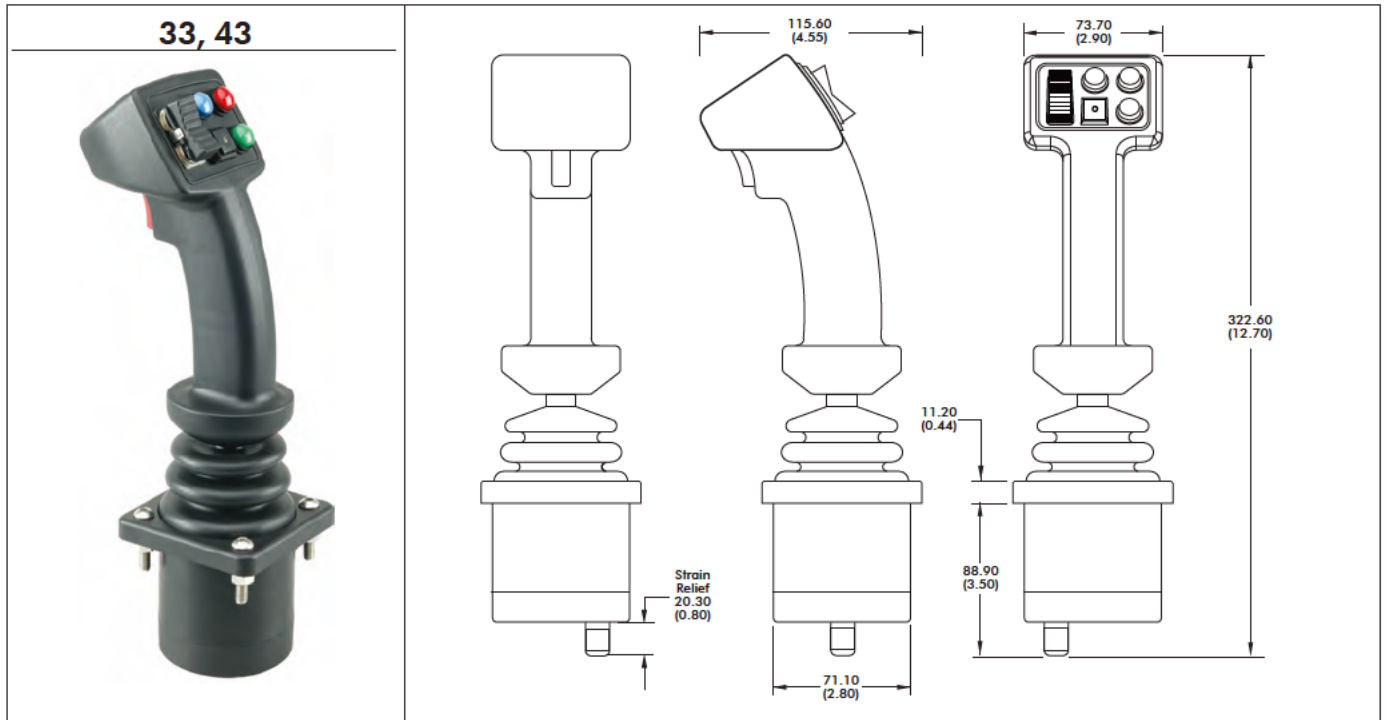

NOTES

1. Dimensions are in mm/(inch)
2. Actual strain relief position may vary.
3. For below panel lower profile housings, the strain relief [20.30/(0.80)] can be replaced with a rubber grommet [1.27/(0.05)], and the standard housing cap [18.54/(0.73)] can be replaced with a short cap [11.94/(0.47)]. These options are available only for joysticks without additional boards, except USB.

4. Axes orientation:

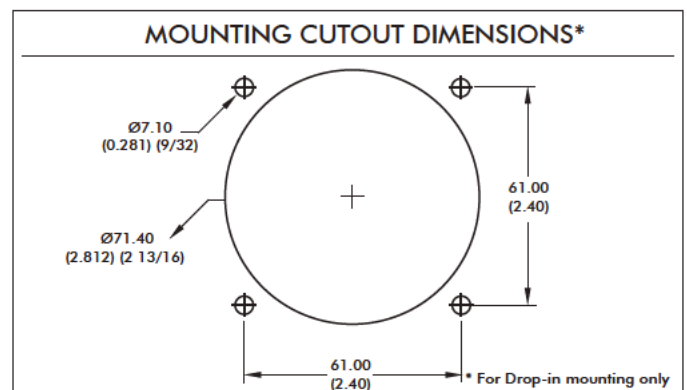
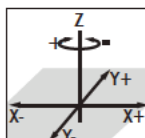

HG series

Hand grip Hall effect joysticks

CONFIGURATION OPTIONS

LINEAR OUTPUT OPTIONS

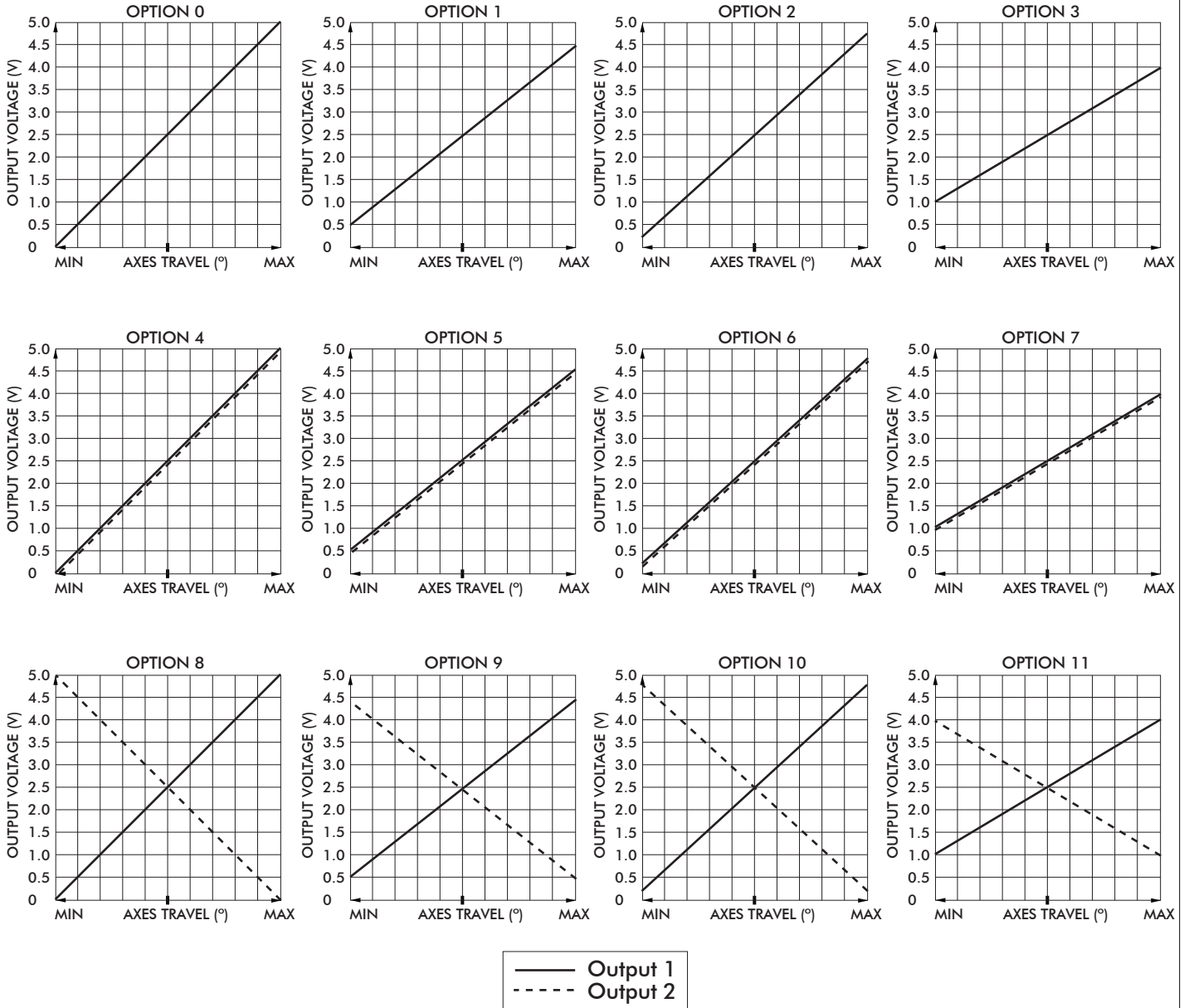

HG series

Hand grip Hall effect joysticks

CONFIGURATION OPTIONS - continued

ADDITIONAL OUTPUT OPTIONS

CANbus J1939

CH Products HG CANbus joysticks conform to the SAE J1939 serial bus specification used for communications between electronic control units and vehicle components. The HG CANbus option provides I/O extension for up to 51 digital and eight analog inputs.

FEATURES

- CANbus J1939
- Extended I/O extension for up to 51 digital and eight analog inputs.
- Accommodates a 6-40VDC power supply
- Operating temperature: -40°C to +85°C (-40°F to +185°F)
- Storage temperature: -60°C to +150°C (-60°F to +302°F)

ELECTRICAL SPECIFICATIONS

Supply Power:	-	6 – 40 VDC
Supply Current:	-	15mA min, +5mA per LED, +6mA per axis

WIRING SPECIFICATION

Red Wire	-	Supply Power
Black Wire	-	Ground
Green Wire	-	CAN high data
White Wire	-	CAN low data
Blue Wire	-	Identifier Select
Orange Wire	-	Identifier Select

CONNECTOR OPTIONS:

- Cable assembly with Deutsch DT04 style plugs
- External i/o harnessing per customer specification

CANbus CONFIGURATION CHART

- Contact factory for assistance

BAUD RATE (Check one)		250K	500K	1000K		BLUE WIRE	ORANGE WIRE
11 BIT IDENTIFIER (CAN2.0A) (Hex)	#1 TX	1	0			G	G
	RX						
	#2 TX						G
	RX						
29 BIT IDENTIFIER (CAN2.0B) (Hex)	#3 TX					G	
	RX						
	#4 TX						
	RX						
8 BYTE TX DATA FRAME (Binary)	#1 TX	3	2	1	0	G	G
	RX						
	#2 TX						G
	RX						
8 BYTE RX DATA FRAME (Binary)	#3 TX					G	
	RX						
	#4 TX						
	RX						
AXIS DATA TYPE (Check one)	SIGNED CHAR (+/-127)	UNSIGNED CHAR (0-255)	UNSIGNED INT (0-1023)	UNSIGNED INT (0-4095)		IDENTIFIER SELECT WIRES (SUPPLIED IN PIGTAIL) G TIED TO 0V (BLACK WIRE)	

HG series

Hand grip Hall effect joysticks

CONFIGURATION OPTIONS - continued

ADDITIONAL OUTPUT OPTIONS

PLUG-AND-PLAY SOLUTIONS:

USB

Featuring USB 1.1 HID compliant interface, CH Products' USB joysticks are recognized as standard HID "game controller" devices. Adhering to the HID specification, CH Products' USB joysticks are plug-and-play with most versions of Windows and Linux. Joystick button and axes assignments are dependent upon the controlled application.

FEATURES

- USB 1.1 HID compliant "game controller" device
- Easy to install and operate
- Functions determined by controlled application
- Standard male type "A" connector



USB Male Type A Connector

SUPPLIED WIRING

USB: USB Male Type A Connector with over-molded cable
(Optional ruggedized military connectors are available.)

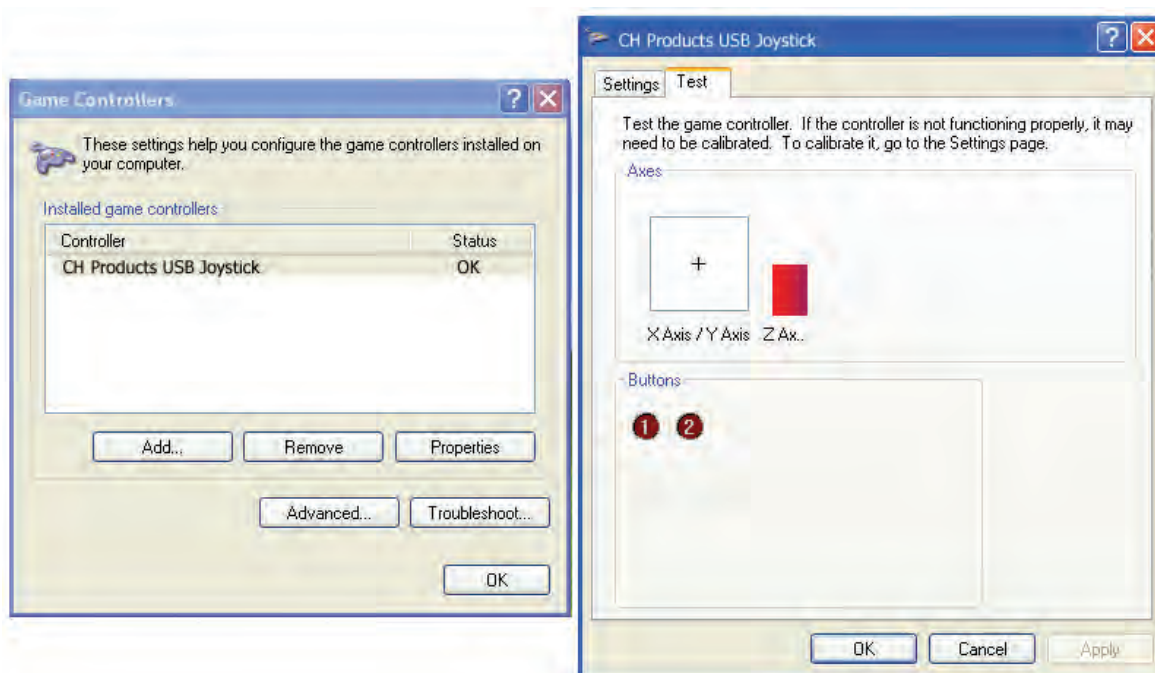

HG series

Hand grip Hall effect joysticks

CONFIGURATION OPTIONS - continued

ADDITIONAL OUTPUT OPTIONS

JOYBALL (CURSOR EMULATION)

The Joyball option converts multi-axis joystick output into a mouse, trackball, or cursor control device. The joystick's internal microprocessor converts absolute axis position into a cursor velocity, which is translated as a relative trackball or mouse position. Supported protocols include Sun Microsystems (mouse systems 5vdc serial) and USB.

APPLICATIONS

The Joyball option is ideal for vehicle applications subjected to dirt and high vibration which make operating a traditional cursor control device difficult. The Joyball option is widely used in shipboard and military applications.

FEATURES

- HID compliant "pointing device"
- Plug-and-play with USB option
- Ideal for marine GPS and navigation
- Environmental sealing up to IP68

SUPPLIED WIRING

USB: USB Male Type A Connector with over-molded cable

SUN: SUN mini-DIN plug with overmolded cable and strain relief

I/O COMPLEMENT/ USER SPECIFIED PARAMETERS:

- USB 4 pushbuttons 2 or 3 axes (X,Y, and Z "scroll")
- SUN 2 pushbuttons and 2 axes (X, Y)

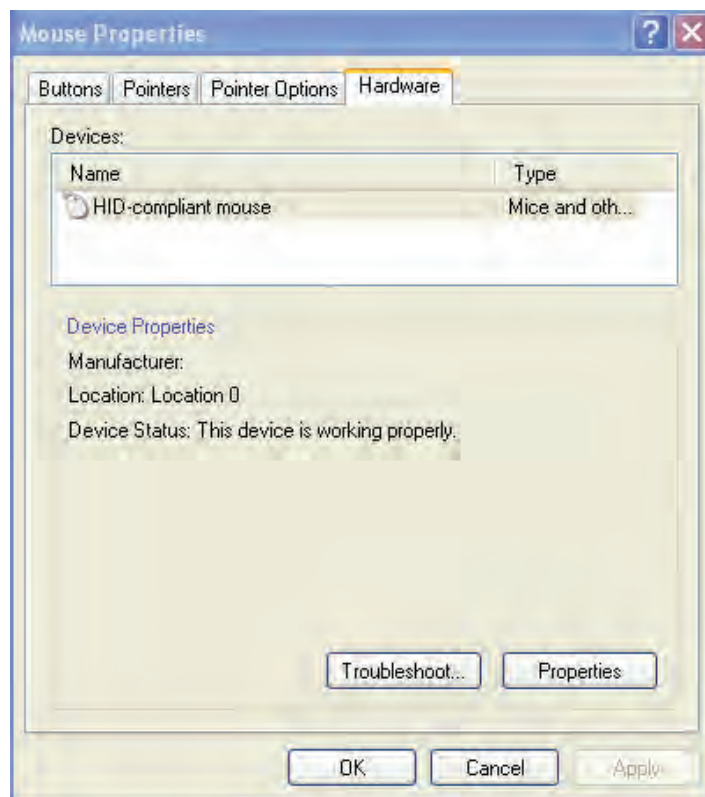

HG series

Hand grip Hall effect joysticks

CONFIGURATION OPTIONS - continued

ADDITIONAL OUTPUT OPTIONS

DUAL DECODE

Dual Decode utilizes a microprocessor to monitor two linear opposite-ramp signals for each joystick axis and provides one proportional (0.5VDC – 4.5VDC) and one logical output accordingly. The dual inversed signals are continuously monitored and a logical signal of 0VDC is provided for over-range (>4.5VDC), under-range (<0.5VDC) and signal tracking (sum of both signals equals 4.5V +/-10%) error. A logical signal of 5.0VDC is provided for a properly functioning joystick deflected from center.

APPLICATIONS

Dual Decode provides a center detect function as well as error tracking, making it ideal for high liability, safety critical applications.

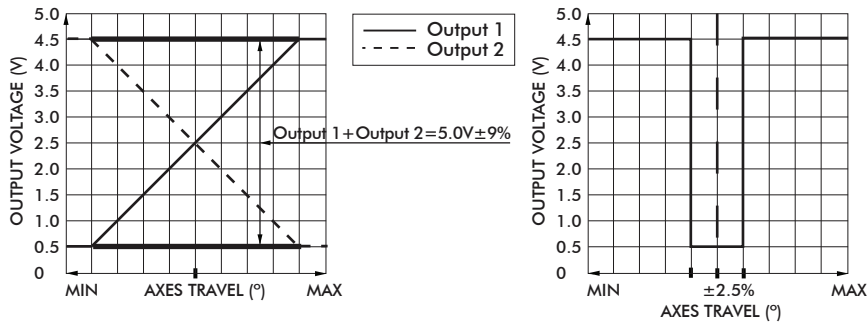

ELECTRICAL SPECIFICATIONS

Supply Power	-	4.5VDC to 5.5VDC
Supply Current	-	30mA + 10mA per axis

WIRING SPECIFICATION

Red wire	-	Customer power supply 4.5VDC-5.5VDC
Black wire	-	Ground
Blue wire	-	X axis output
Yellow wire	-	Y axis output
Green wire	-	Z axis output
Blue/White wire	-	X axis dual decode logic output
Yellow/Black wire	-	Y axis dual decode logic output
Green/Black wire	-	Z axis dual decode logic output
White wire	-	Pushbutton common wire
Orange, violet, gray, brown, pink, bl/wt/y/bk, gn/bk, gy/w wire	-	Pushbutton outputs

ANALOG DEADBAND

Analog Deadband utilizes an analog circuit to monitor proportional joystick outputs and enhance return to center accuracy over multiple axes. Specified for joysticks with normally ranged outputs of 0VDC – 5VDC at full axis travel, a constant output of 2.5VDC is provided for the joystick's position +/-2.5° from center.

APPLICATIONS

Analog Deadband effectively eliminates mechanical return-to-center error, making it ideally suited for safety critical applications susceptible to drift and motion control systems lacking center position trim.

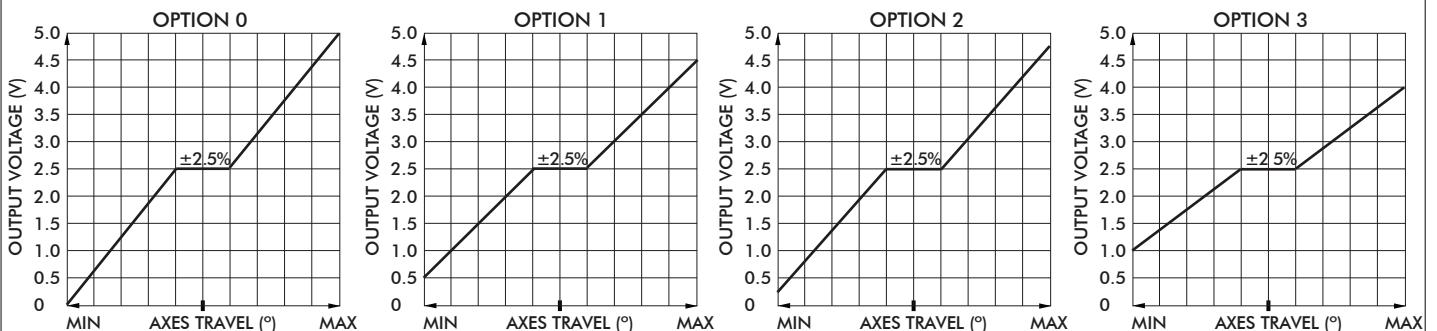

HG series

Hand grip Hall effect joysticks

CONFIGURATION OPTIONS - continued

ADDITIONAL OUTPUT OPTIONS

ELECTRICAL SPECIFICATIONS

Supply Power	-	4.5VDC to 5.5VDC
Supply Current	-	10mA per axis

WIRING SPECIFICATION

Red wire	-	Customer power supply 4.5-5.5vdc
Black wire	-	Ground
Blue wire	-	X axis output
Yellow wire	-	Y axis output
Green wire	-	Z axis output
White wire	-	Pushbutton common wire
Orange,violet,gray,brown,pink,bl/wt/y/bk,gn/bk,gy/w wire	-	Pushbutton outputs

CENTER DETECT

Center Detect utilizes a microprocessor to monitor joystick output and provides both logic and proportional signals for enhanced operator safety. Specified for a joystick normally ranged 0.5VDC to 4.5VDC, the microprocessor continuously monitors the proportional output and provides HI logic signal (5.0VDC) when moved off center and an LO logical signal (0VDC) for an over-range (>4.5VDC) or under-range (<0.5VDC).

APPLICATIONS

Center Detect is ideal for safety critical applications including master relay control "MCR" for a motion control system or as a brake release for an overhauling load.

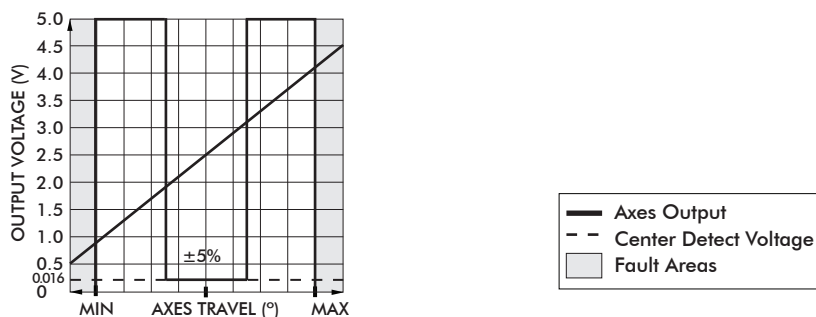

ELECTRICAL SPECIFICATIONS

Supply Power	-	4.5V to 5.5V
Supply Current	-	30mA + 10mA per axis

WIRING SPECIFICATIONS

Red Wire	-	Power supply 4.5 - 5.5VDC
Black Wire	-	Ground
Blue Wire	-	X axis output
Yellow Wire	-	Y axis output
Green Wire	-	Z axis output
Blue/White Wire	-	X axis center detect logic output
Yellow/Black Wire	-	Y axis center detect logic output
Green/Black Wire	-	Z axis center detect logic output
White Wire	-	Pushbutton common wire
Orange,violet,gray,brown,pink,bl/wt,y/bk,gn/bk,gy/w wire	-	Pushbutton outputs

HG series

Hand grip Hall effect joysticks

CONFIGURATION OPTIONS - continued

ADDITIONAL OUTPUT OPTIONS

DISCRETE OUTPUT

Discrete Output is a microprocessor based option providing up to 6 hi voltage/hi current, on/off outputs as well as proportional outputs. Featuring a microcontroller, an a/d converter, and 4 to 8 optically isolated solid state switches, the Discrete Output provides an electronic "switch stick" function. Switch combinations and firing angles are programmed to the application's requirement.

APPLICATIONS

The Discrete Output option is designed for small motor, reversing starters or hydraulic solenoid actuations.

DC SPECIFICATIONS

Supply Voltage Operating	-	5.0- 40VDC input power
Supply Current	-	30mA + 10mA per hall sensor
Sourcing Outputs	-	70V AC/DC @ 1.6A max.
Sinking Outputs	-	70V AC/DC @ 3.6A max.
Discrete Output Max	-	60VDC/AC, 3.2A per discrete output

WIRING

Red Wire	-	Customer power supply 5 - 40VDC
Black Wire	-	Ground
Blue Wire	-	X axis output
Yellow Wire	-	Y axis output
Green Wire	-	Z axis output
Blue/White Wire	-	X axis discrete output
Yellow/Black Wire	-	Y axis discrete output
Green/Black Wire	-	Z axis discrete output
White Wire	-	Pushbutton common wire
Orange,violet,gray,brown,pink,bl/wt,y/bk,gn/bk,gy/w wire	-	Pushbutton outputs

I/O COMPLEMENT AND USER SPECIFIED PARAMETERS:

Up to 3 axes and 6 discrete sourcing or sinking outputs.

DISCRETE OUTPUT CONFIGURATION FORM:

Discrete Output	Sourcing	Sinking	AC	DC
Xfwd				
Xrev				
Yfwd				
Yrev				
Zfwd				
Zrev				

SAMPLE OF COMPLETED FORM:

(Please enter required choices for each applicable axis and return form to factory.)

Discrete Output	Sourcing	Sinking	AC	DC
Xfwd		X		X
Xrev		X		X
Yfwd	X			X
Yrev	X			X
Zfwd		X		X
Zrev		X		X

HG series

Hand grip Hall effect joysticks

CONFIGURATION OPTIONS - continued

ADDITIONAL OUTPUT OPTIONS

VOLTAGE REGULATOR

The Voltage Regulator is a multi-wired analog option to mate a Hall effect joystick to a variety of industrial control voltages. The Voltage Regulator may be used when the supply or output voltage is greater than 5V or when bipolar output is required.

User Specified Supply Voltage:

- 5 VDC
- 10 VDC
- 12 VDC
- 24 – 30 VDC
- Custom supply options available.

User Specified Output Voltage:

- 0-5 VDC
- 0-10 VDC
- +/-5 VDC
- +/-10 VDC
- Custom outputs available.

ELECTRICAL SPECIFICATIONS

Supply Power	-	5VDC to 30VDC
Supply Current	-	90mA max

WIRING SPECIFICATION

Red wire	-	Supply power 5-30VDC
Black wire	-	Ground
Blue wire	-	X axis output
Yellow wire	-	Y axis output
Green wire	-	Z axis output
White wire	-	Pushbutton common wire
Orange,violet,gray,brown,pink,bl/wt/y/bk,gn/bk,gy/w wire	-	Pushbutton outputs

