



# SOCOJE

SOCOJE INTELLIGENT TECHNOLOGY

## Anti vandal switch $\phi 19\text{mm}$

### APPLICATIONS / MARKETS



### ORDER CODE

Series	Actuator Options	Terminal Options	Function Options	Material Options	Graphic Options
V19	F- Flat H- High B- Domed	P- Solder lug (2.8x0.5) NONE- Screw	Momentary 1- NO	S- Stainless steel N- Nickel plated brass A- Anodized aluminum G- Gold plated brass	NONE- Non-marking LE- Laser etched

### DESCRIPTION

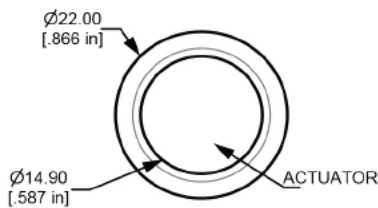

Panel Thickness: 1~8mm

### TECHNICAL DATA

Type	V19-F	V19-B	V19-H
Actuator Options	Flat Actuator	Domed Actuator	High Actuator
Terminal	Screw/ Solder (2.8X0.5)		
Max. Switch Rating	2A 48VDC		
Contact Resistance	$\leq 50\text{m}\Omega$		
Insulation Resistance	$\geq 1000\text{m}\Omega$		
Dielectric Strength	2000VAC		
Operation Temp	$-20^\circ\text{C} \sim +55^\circ\text{C}$		
Mechanical Life	1,000,000 Cycles		
Electrical Life	200,000 Cycles		
Contact Material	Silver Alloy		
Torque	5 ~ 14Nm		
Operation Pressure	approx. 4N		
Protection	IP65/ IK08		
Material			
Actuator	Stainless steel/ Gold or Nickel plated brass/ Anodized aluminum		
Body	Stainless steel/ Gold or Nickel plated brass/ Anodized aluminum		
Base	PBT		

### ACTUATOR OPTIONS

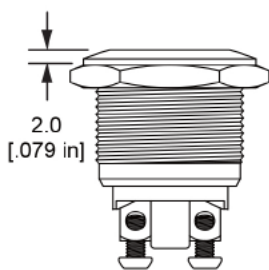

Flat Actuator

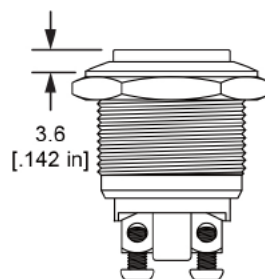

High Actuator

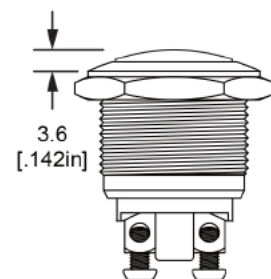

Domed Actuator

# Anti vandal switch $\phi 19\text{mm}$

## SOLDER TERMINAL

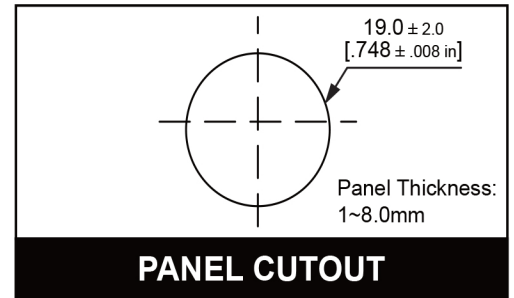
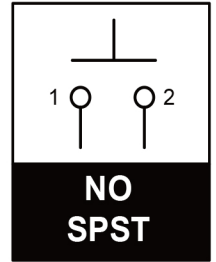
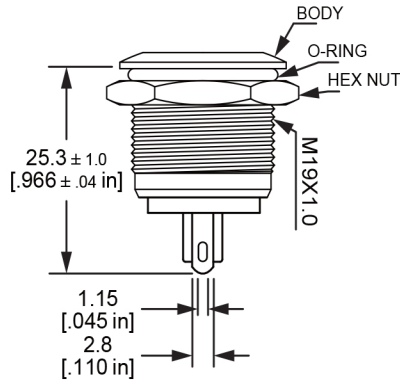
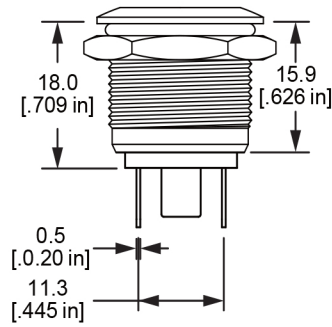

## SCREW TERMINAL

