

Anti vandal switch $\phi 22\text{mm}$

APPLICATIONS / MARKETS



ORDER CODE

Series	Actuator Options	Terminal Options	Function Options	Material Options	Graphic Options
V22	F- Flat H- High B- Domed	P- Solder lug (2.8x0.5) NONE- Screw	Momentary 1- NO	S- Stainless steel	NONE- Non-marking LE- Laser etched

DESCRIPTION

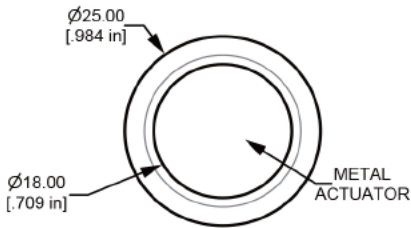

Panel Thickness: 1~8mm

TECHNICAL DATA

Type	V22-F	V22-B	V22-H
Front Shape	Flat	Domed	High Flat
Terminal	Screw/ Pin (2.8X0.5)		
Max. Switch Rating	2A 48VDC		
Contact Resistance	$\leq 50\text{m}\Omega$		
Insulation Resistance	$\geq 1000\text{m}\Omega$		
Dielectric Strength	2000VAC		
Operation Temp	$-20^\circ\text{C} \sim +55^\circ\text{C}$		
Mechanical Life	1,000,000 Cycles		
Electrical Life	200,000 Cycles		
Contact Material	Silver Alloy		
Torque	5 ~ 14Nm		
Operation Pressure	approx. 5.5N		
Protection	IP65/ IK09		
Material			
Actuator	Stainless Steel		
Body	Stainless Steel		
Base	PBT		

ACTUATOR OPTIONS

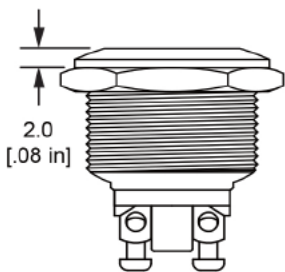

Flat Actuator

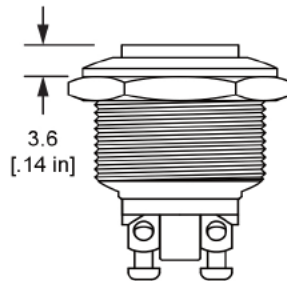

High Actuator

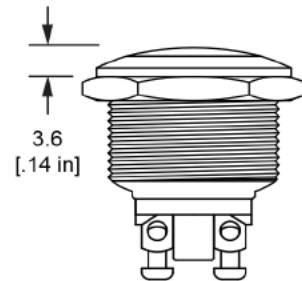

Domed Actuator

Anti vandal switch $\phi 22\text{mm}$

SOLDER TERMINAL

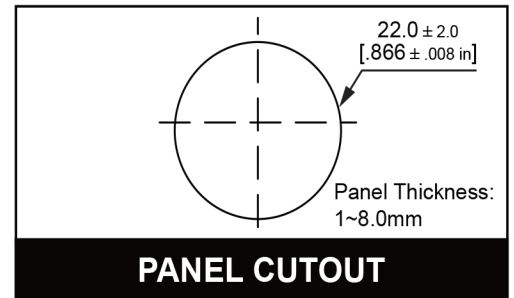
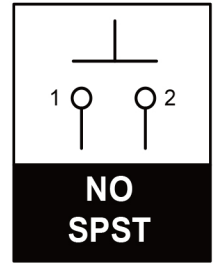
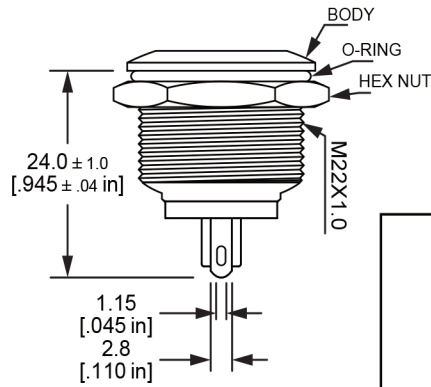
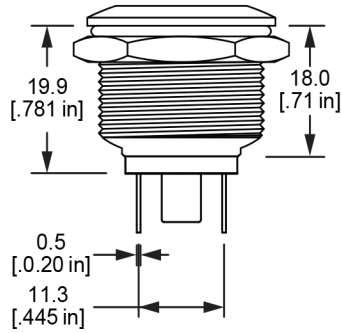

SCREW TERMINAL

