

Specifications

Rating:	15A 250VAC
Contact Resistance:	25mΩ Max
Insulation Resistance:	100MΩ Min
Dielectric Strength:	1000VAC 1 minute
Operating Temperature:	-25°C to +80°C
Electrical Life:	100,000+ Cycles

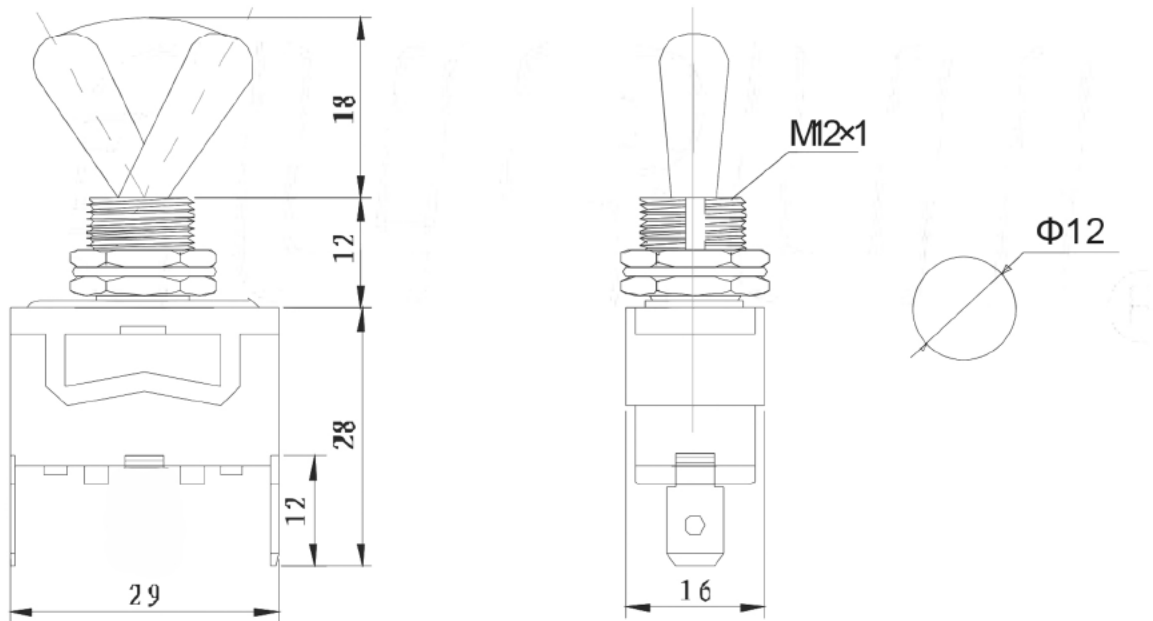

Description	Ref Code
On-Off SPST Toggle Switch 250V AC 15A	112034