

Specifications

Rating:	15A 250VAC, 20A 125VAC
Contact Resistance:	50mΩ Max
Insulation Resistance:	1000MΩ Min
Dielectric Strength:	1500VAC 1 minute
Operating Temperature:	-25°C to +85°C
Electrical Life:	10,000+ Cycles

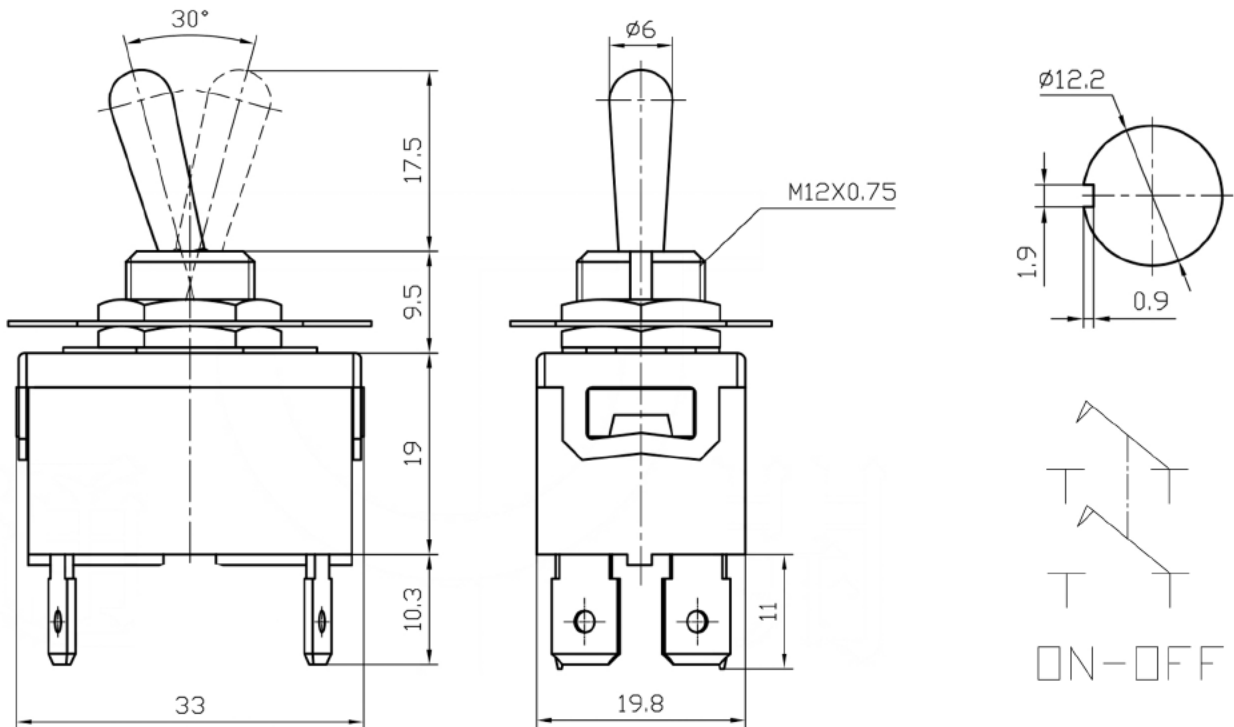

Description	Ref Code
On-Off Toggle Switch DPST 15A 250VAC	112014