

Specifications

| | |
|------------------------|------------------|
| Rating: | 3A 250VAC |
| Protection Level: | IP67 |
| Operating Force: | 300gf |
| Contact Resistance: | 50mΩ Max |
| Insulation Resistance: | 100MΩ Min 500VDC |
| Electrical Life: | 100,000+ Cycles |

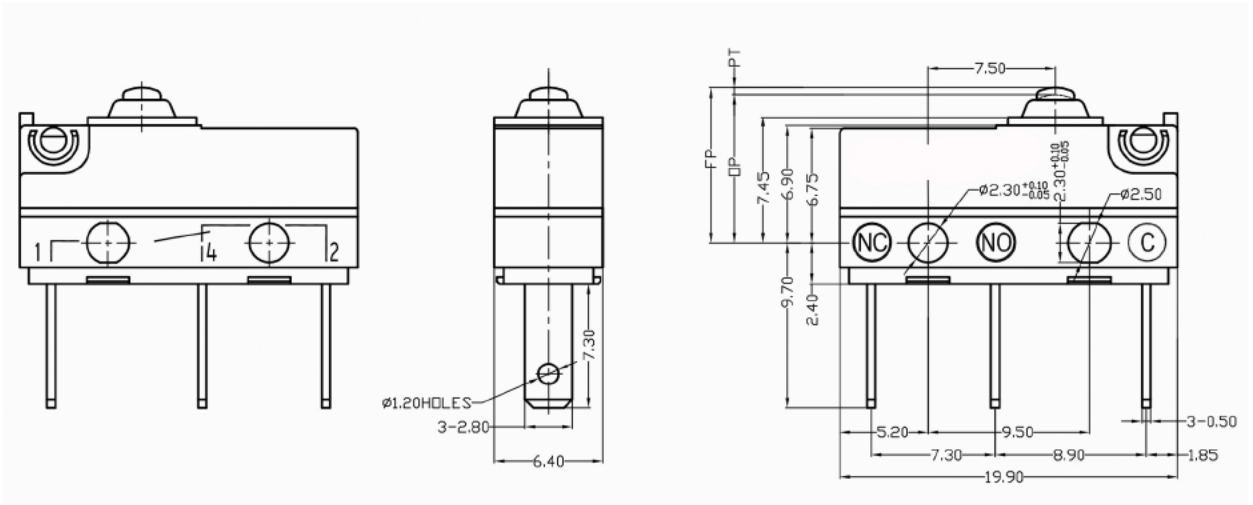

Circuit Diagram

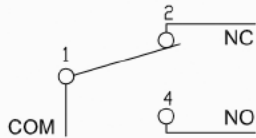

Mounting Hole Dimensions

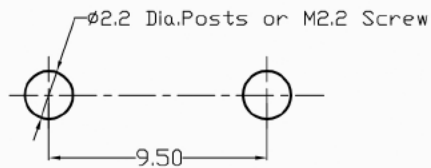

| Description | Ref Code |
|--|----------|
| 17mm Lever Waterproof Microswitch SPDT 3A | 481701 |