

REV.	DATE	REVISION DESCRIPTION
	05/19/04	ORIGINAL

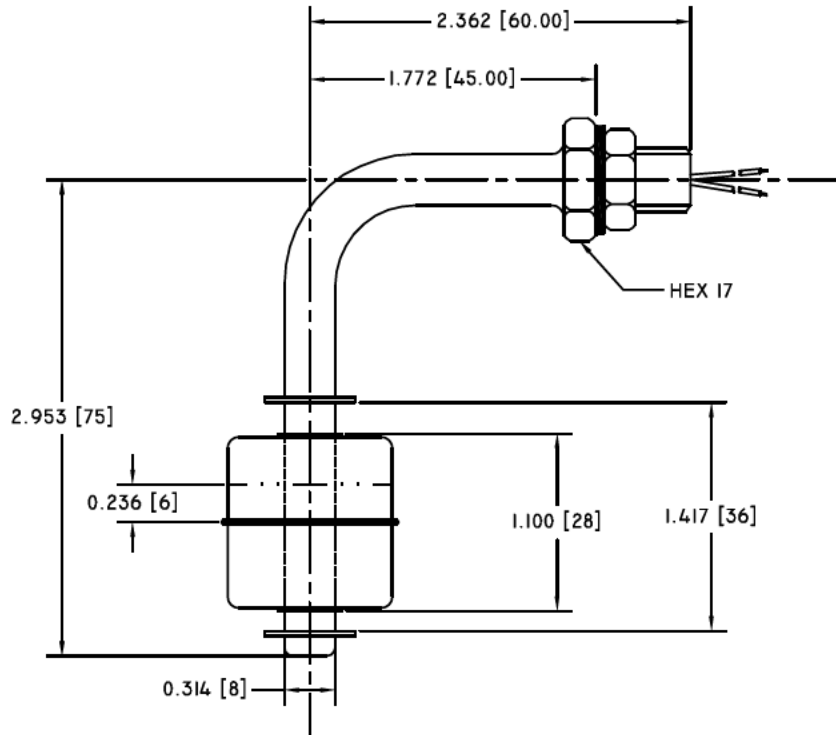

NOTES:

- 1. ELECTRICAL
 - 1.1 SWITCHING CAPACITY MAX. 50W. SPST.
 - 1.2 SWITCHING VOLTAGE MAX. 240VAC / 200VDC
 - 1.3 SWITCHING CURRENT MAX. 0.5A.
 - 1.4 CARRY CURRENT MAX. 1A.
- 2. OPERATIONAL:
 - 2.1 SIDE MOUNTING
 - 2.2 REVERSIBLE SWITCH ACTION
 - 2.3 NORMAL OPEN (N.O.) SPST.
 - 2.4 OPERATING TEMPERATURE -10°C TO 128°C
 - 2.5 MAX. PRESSURE 10 (Kg/cm)
 - 2.6 SUITABLE SPECIFIC GRAVITY OF LIQUID 0.8
- 3. FINISH:
 - 3.1 STAINLESS STEEL SUS304,316
 - 3.2 LEAD WIRE UL3266, AWG 22

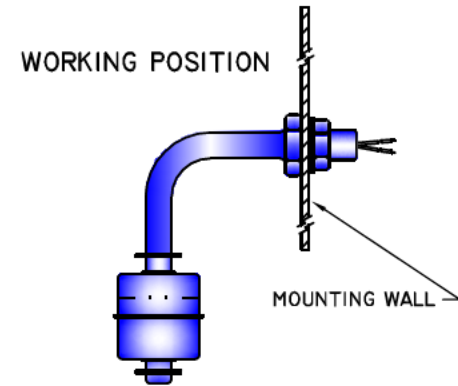
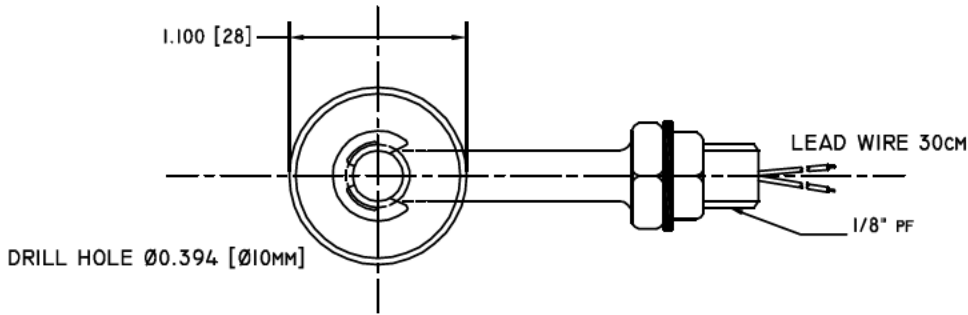

ENGINEERING		
QUALITY		
PRODUCTION		
APPROVAL	SIGNATURE	DATE

UNSPECIFIED TOLERANCES
 DECIMAL: .XX ±.01 [.254]
 .XXX ±.005 [.127]
 FRACTIONAL: ± 1/64 [.397]
 ANGULAR: ± 1/2°

REF.: VFS-30	SCALE: 5:4	DRAWN BY: R. F.	DATE 05/19/2004
TITLE: FLOAT SWITCH			
TYPE: PRODUCTION		DRAWING #: HFS30	