Specification

Appellation: Microswitch

Model: XZ-15GW2-B

1. Features & Application

- Adopt thermosetting plastic or thermoplastic
- Small contact gap,snap action,high sensitivity and small operating travel
- Variety of levers
- Widely used in appliance,electronic equipment ,automatic machine,communication equipment,car electric,apparatus and instrument,electro motion tool etc

2. Model & Meanings

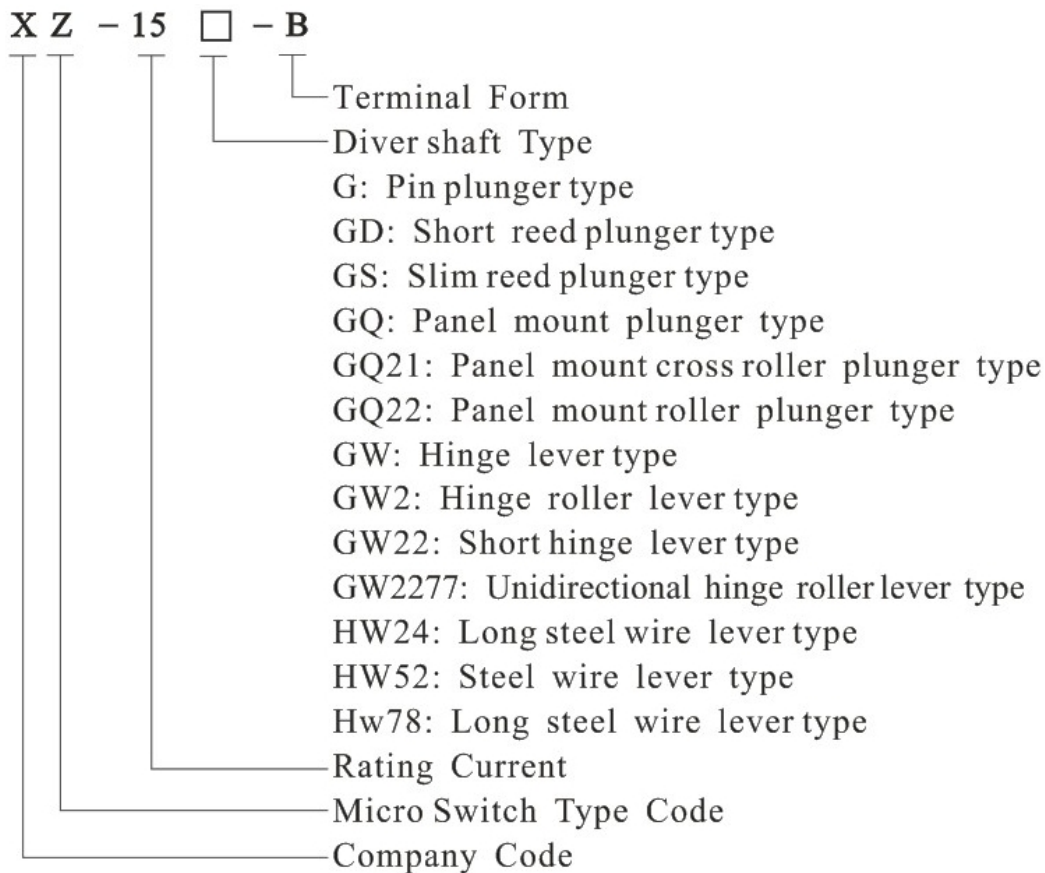

3. Technical Specification

Item	Data	
Operation speed	0.1mm-1m/s	
Operation frequency	Mechanical	240times / second
	Electrical	20times/second
Insulation resistance	100MΩ	
Contact resistance	25 MΩ(initial value)	
Withstand Voltage	Non-connection wire	1500VAC
	Every terminal	2000VAC
Vibration	Misoperation	10-55HZ(amplitude)1.5mm

Impact	Durable	1000m/s
	Misoperation	300m/s
Life	Electrical	100,000times above
	Mechanical	1,000,000times above
Protection degree	IP40	
Ambient operating temperature	-25-80℃	
Humidity	<85%	

Rating voltage (V)	Rating current (A)	Ith current (A)
AC-250	7.5	10
AC-125	15	20
DC-250	0.3	0.45
DC-125	0.6	0.75

4. Outshape and mounting dimensions.

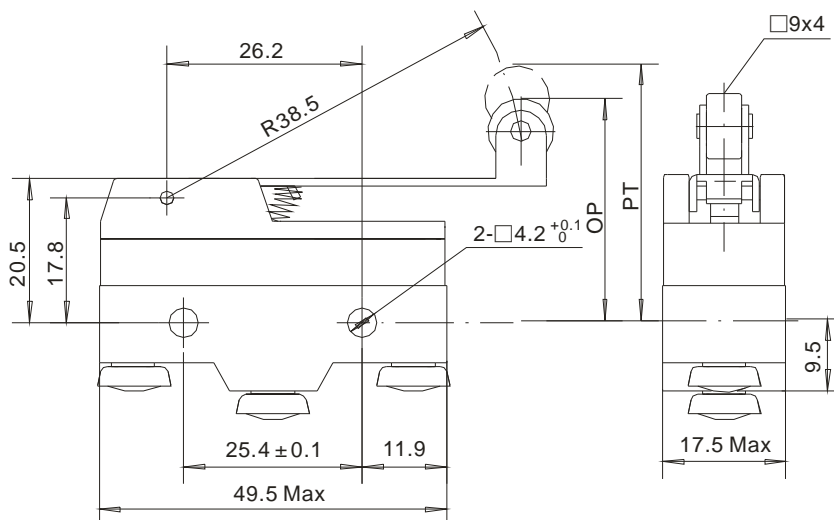

5. Connection Diagram

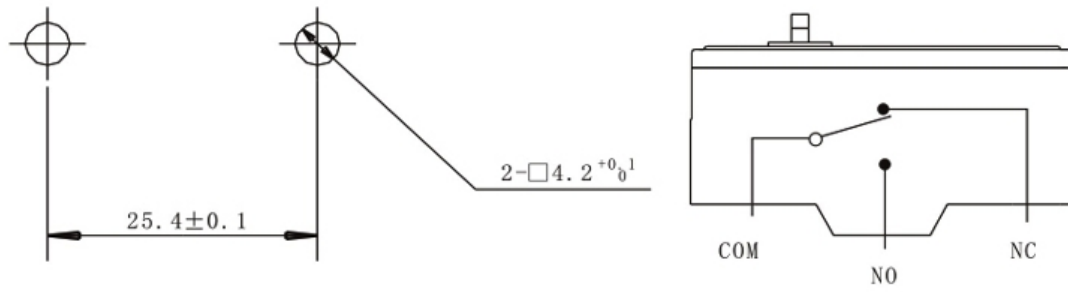

6. Certifications

CCC, CE, UL,