SPECIFICATION

Product Name: Switch Switch

XZ-15GW21-B



1. Features & Application

- Adopt thermosetting plastic or thermoplastic;
- Small contact gap, snap action, high sensitivity and small operating travel;
- Variety of levers;
- Widely used in appliance, electronic equipment, automatic machine, communication equipment, car electric, apparatus and instrument, electro motion tool etc.

2. Model & Meanings

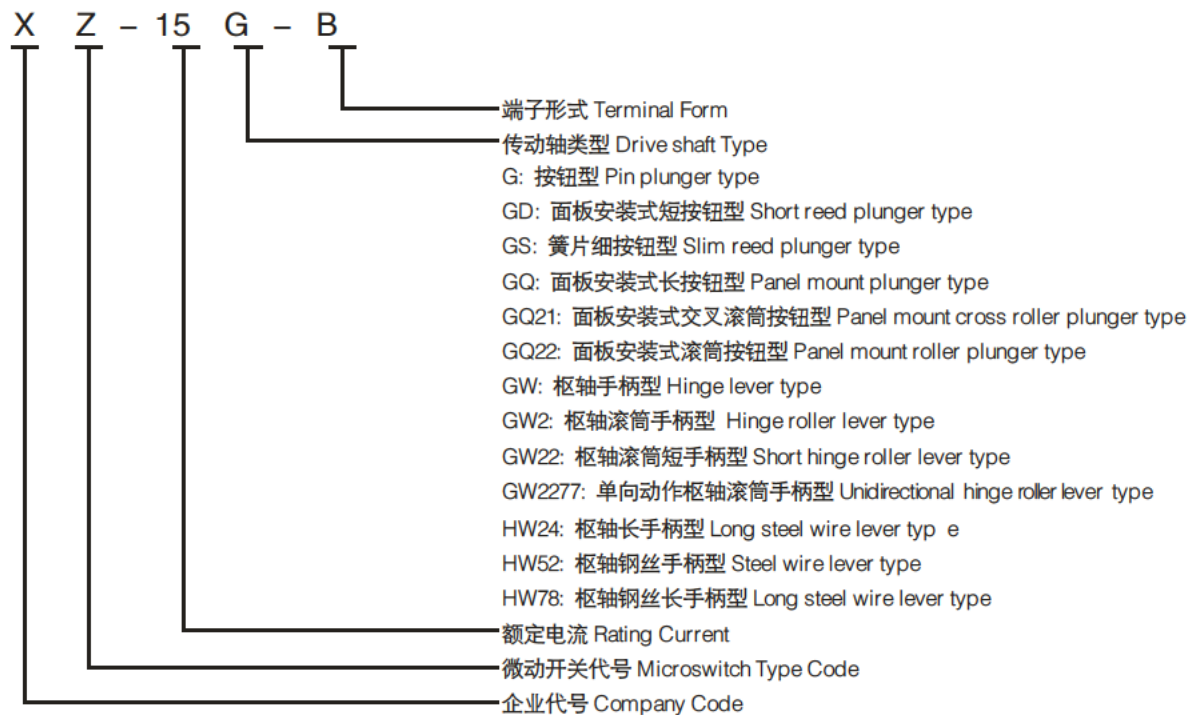

3. Technical Specification

项 目 Item	参数值 Data	
操作速度 Operating speed	1mm-1m/s	
操作频率 Operating frequency	机 械 Mechanical	240次/分 240 times/min
	电 气 Electrical	20次/分 20 times/min
绝缘电阻 Insulation resistance	100MΩ 以上(Above) DC500V	
接触电阻 Contact resistance	25mΩ (初值 initial value)	
介质耐压 Withstand voltage	非 连 线 Non-connection wire	1000VAC
	各端子间 Every terminal	1500VAC
振 动 Vibration	误 动 作 Misoperation	10-55Hz 复振幅 Amplitude 1.5mm
	耐 久 Durable	1000m/s ²
冲 击 Impact	误 动 作 Misoperation	300m/s ²
	电 气 Electrical	100,000次以上 above
寿 命 Life	机 械 Mechanical	1,000,000次以上 above
	防 护 等 级 Protection degree	IP40
使用温度 Operating temperature	-25~+80°C	
使用湿度 Operating humidity	<85%	

额定电压Ue(V)	额定电流Ie(A)	发热电流Ith(A)
AC-250	15	20
AC-125	15	20
DC-250	0.3	0.45
DC-125	0.6	0.75

4. Outshape and mounting dimensions

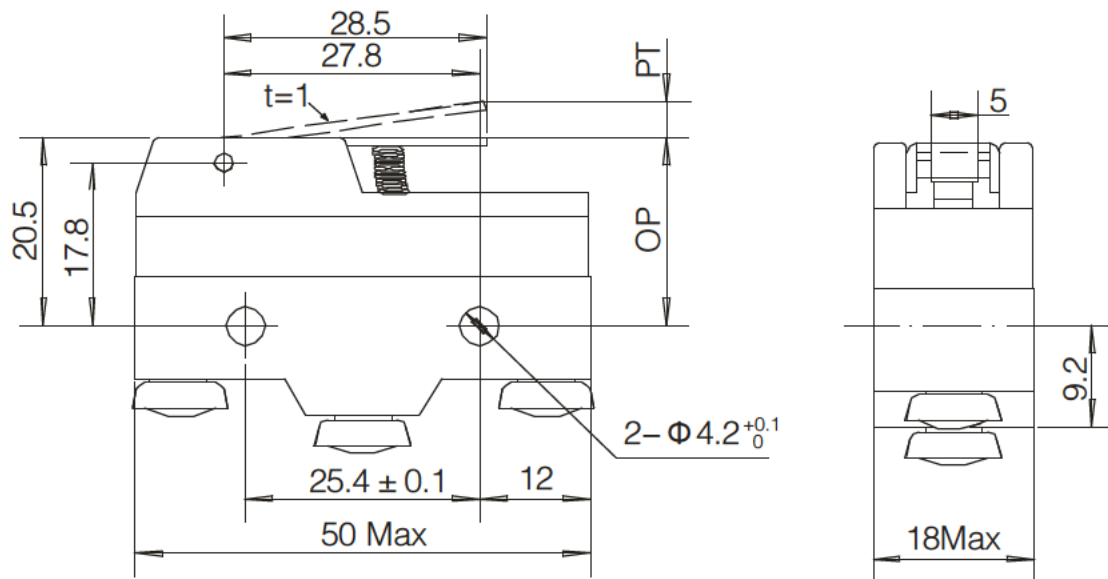

动作力	OF	160g(1.57N)
回复力	RF min.	25g(0.25N)
预行程	PT max.	4mm
超行程	OT min.	2mm
差行程	MD max.	0.5mm
动作位置	OP	19±0.8mm

5. Contact Form

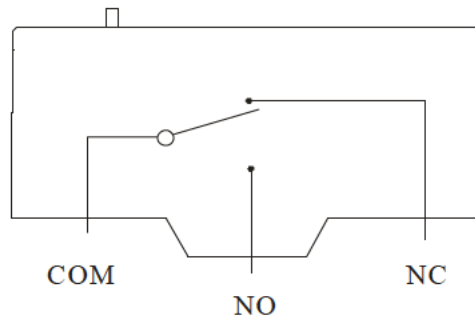

6. Structure

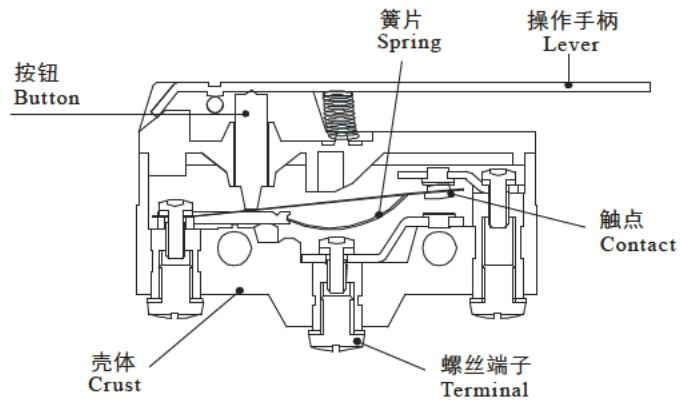

7. Terminal

