

DETECTOR SWITCH TE-MR SERIES

Detector Horizontal Type

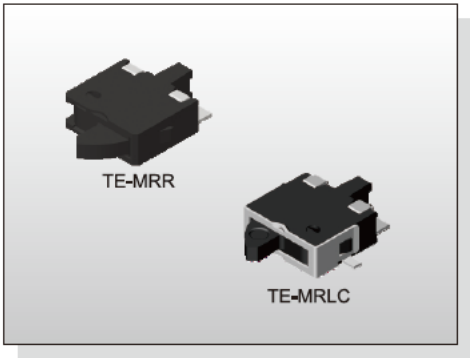

FEATURES

※Left or right operation direction

APPLICATION

- ※Close/open detection
- ※White goods
- ※Automotive

SPECIFICATION

| | |
|-----------------------|--------------------|
| Contact Rating | 50mA, 20V DC |
| Contact Resistance | 1Ω max. |
| Insulation Resistance | 100MΩ min, 100V DC |
| Dielectric Strength | 100V AC/1 minute |
| Operating Force | 50gf max. |
| Travel | 2.15mm |
| Operating Life | 100,000 cycles |
| Operating Temp. | -10°C ~ +60°C |
| Storage Temp. | -20°C ~ +70°C |

HOW TO ORDER

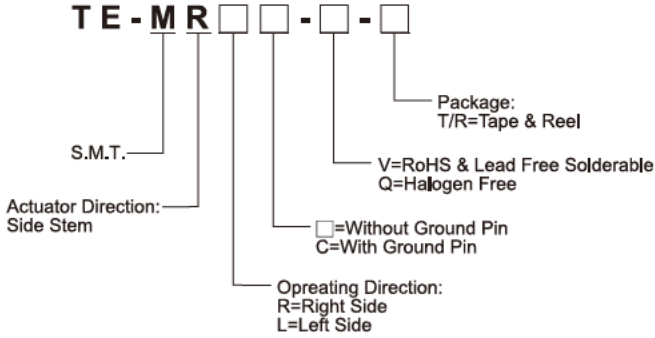

CIRCUIT

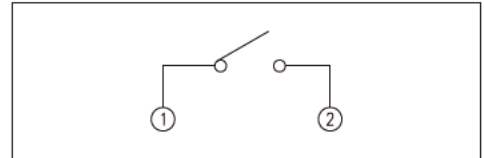

PACKAGE

<Tape & Reel>

TE-MR []: 3000 pcs
TE-MR [] C: 2000 pcs

TE-MRR

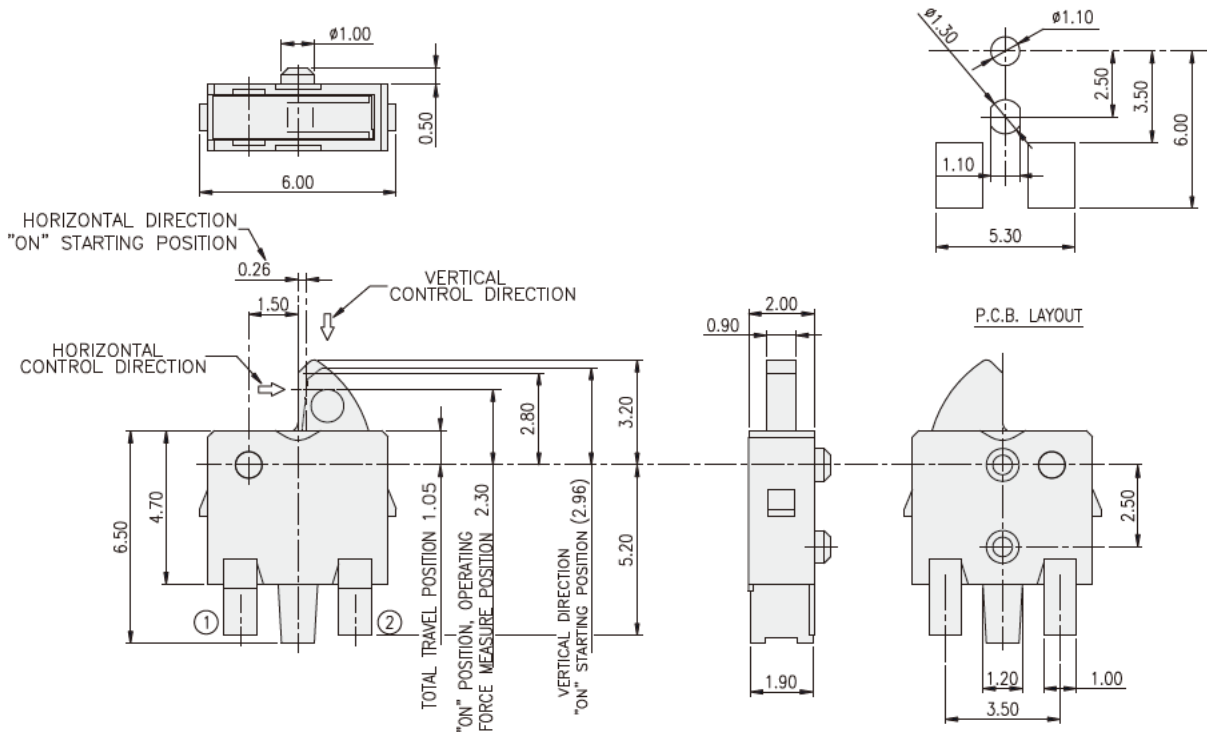

TE-MRLC

