

**FEATURES**

- ※ Thinner type 2.5mm height
- ※ High density mounting
- ※ With anti-ESD of ground terminal

**APPLICATION**

- ※ Consumer products
- ※ Instrumentation
- ※ Industrial

**SPECIFICATION**

Contact Rating	50mA, 12V DC
Contact Resistance	100mΩ max.
Insulation Resistance	100MΩ min. 500V DC
Dielectric Strength	300V AC/1 minute
Operating Force	160±50gf, Brown(N) 260±50gf, Red(R)
Travel	0.25mm
Operating Life	20,000 cycles for 260gf 50,000 cycles for 160gf
Operating Temp.	-25°C ~ +70°C
Storage Temp.	-30°C ~ +80°C

**HOW TO ORDER**

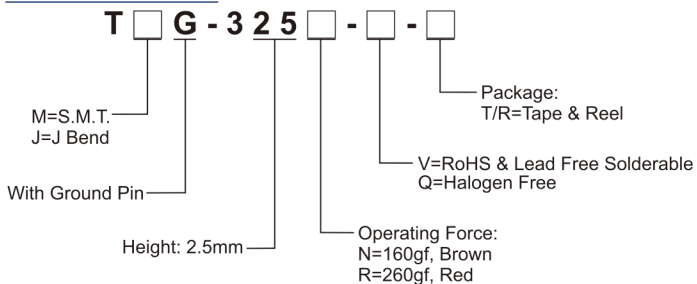

**CIRCUIT**

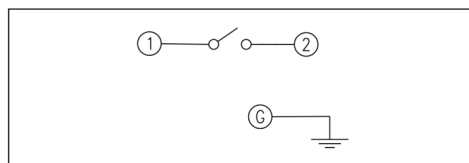

**PACKAGE**

<Tape & Reel>  
2800 pcs

TACT SWITCH

**TMG-325**

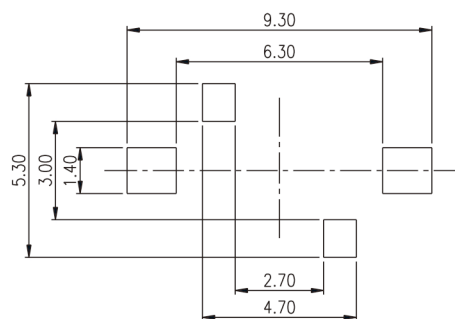
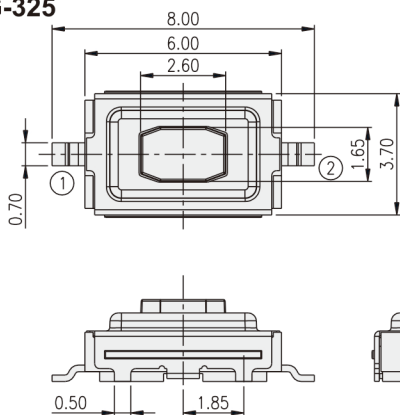

P.C.B. LAYOUT

**TJG-325**

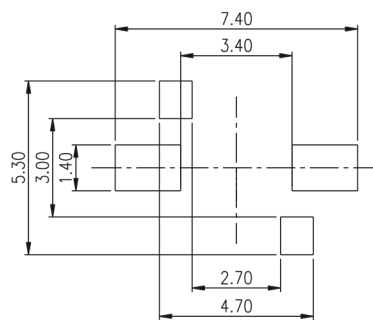
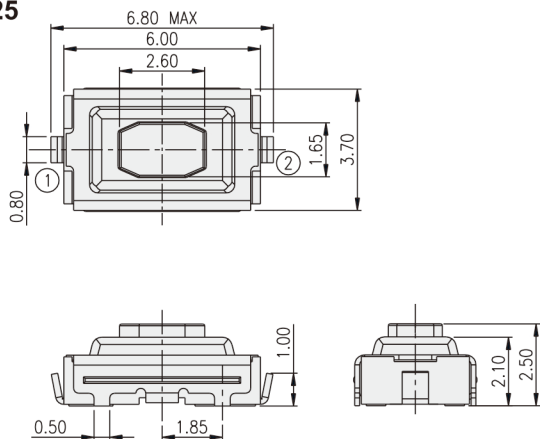

P.C.B. LAYOUT