

ILLUMINATED SWITCH TL(L)(M)-6 SERIES

**Tact Switch
Illuminated**

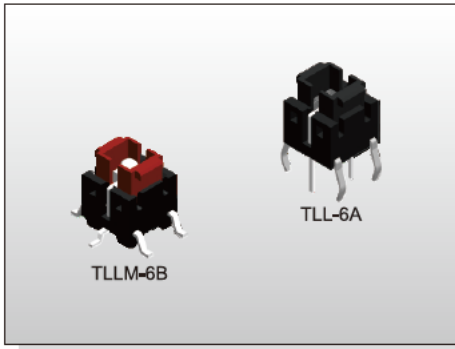

ILLUMINATED SWITCH



FEATURES

- ※ Super bright LED
- ※ Various LED colors
- ※ Options of different cap color

APPLICATION

- ※ Server
- ※ Laptop, IPC
- ※ Set-top box

SPECIFICATION

Contact Rating	50mA, 12V DC	
Contact Resistance	100mΩ max.	
Insulation Resistance	100MΩ min, 500V DC	
Dielectric Strength	250V AC/1 minute	
Operating Force	100±50gf	TL(L)-61
	160±50gf	TL(L)-62
	260±50gf	TL(L)-63
	520±130gf	TL(L)-65
Travel	0.2mm	
Operating Life	200,000 cycles for 520/260gf 500,000 cycles for 160/100gf	
Operating Temp.	-25°C ~ +70°C	
Storage Temp.	-30°C ~ +80°C	

HOW TO ORDER

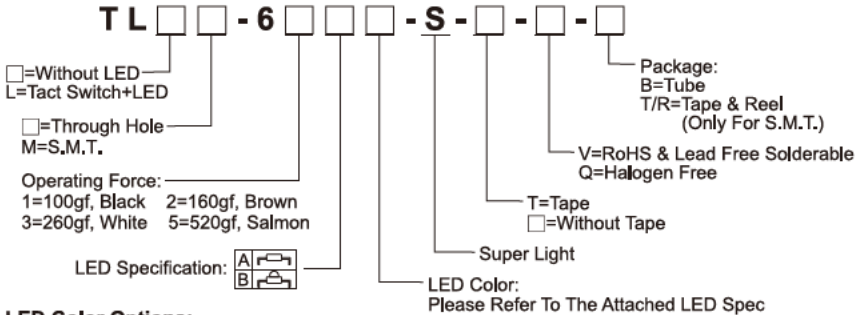

LED Color Options:

Part No.	Color	Dominant Wavelength λ _p Typ.(nm)	Luminous Intensity I _v (mcd)		Forward Voltage V _f (V)		View Angle 2-θ _{1/2} (Degree)	
			A	B	Typ.	Max.	A	B
B	Blue	470	70	1100	3.0	3.6	140°	30°
PG	Pure Green	520	160	2500	3.2	3.6		
G	Yellow Green	570	30	550	2.0	2.3		
Y	Yellow	590	60	1500	2.0	2.3		
A	Soft Orange	605	50	1500	2.0	2.3		
O	Red Orange	620	80	3000	2.0	2.3		
R	Red	630	60	1000	2.0	2.3		
W	Cold White	X:0.30 / Y:0.30	350	550	3.0	3.6		

CIRCUIT

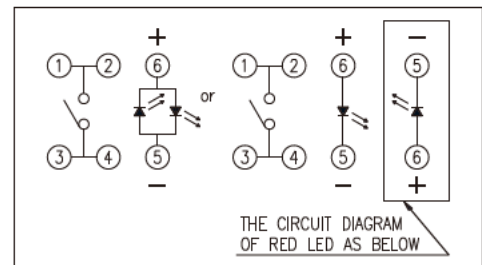

PACKAGE

- <Tube>
75 pcs. (Only for TLL-6)
- <Tape & Reel>
450 pcs. (Only for TLLM-6)

TLL-6 A

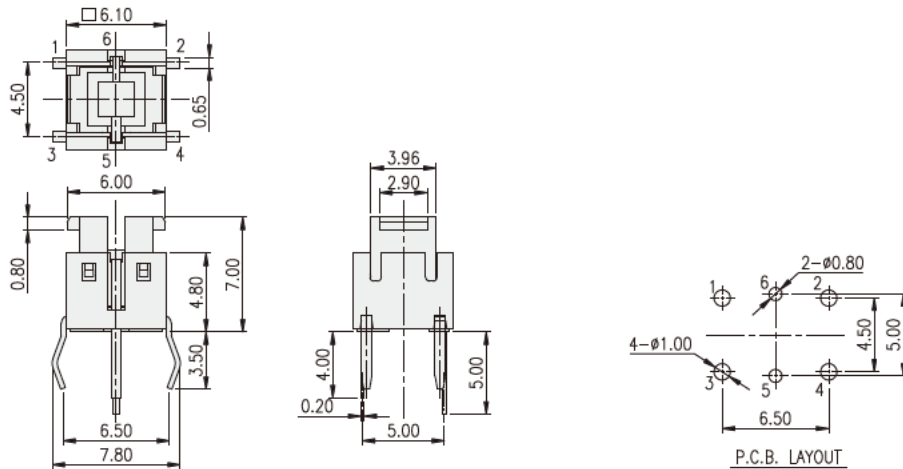

TLLM-6 B

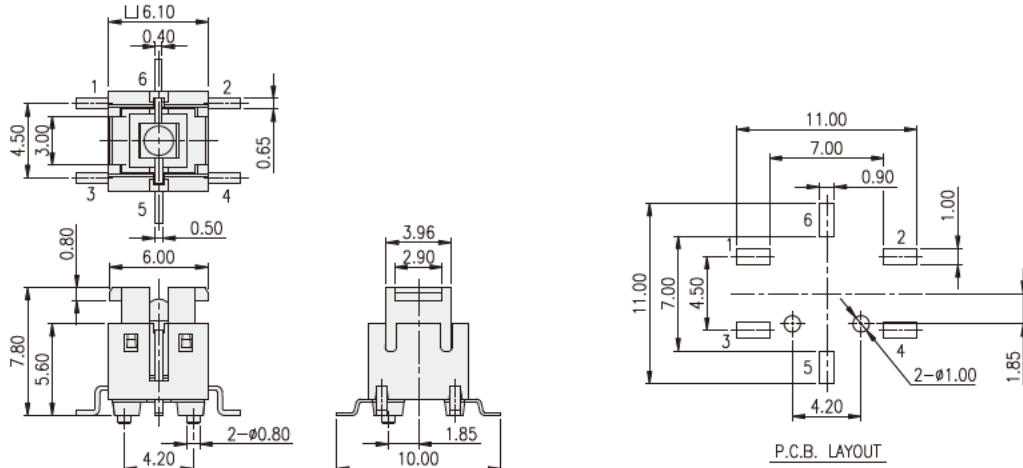

ILLUMINATED SWITCH TL(L)(M)-6 SERIES

**Tact Switch
Illuminated**

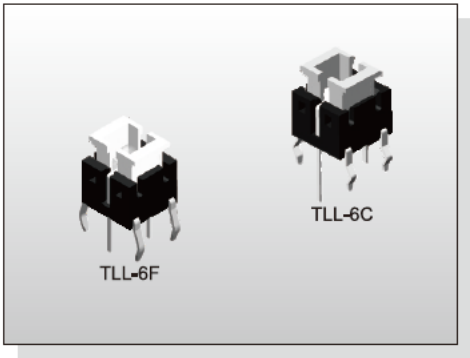

FEATURES

- ※ Super bright LED
- ※ Various LED colors
- ※ Options of different cap color

APPLICATION

- ※ Server
- ※ Laptop, IPC
- ※ Set-top box

SPECIFICATION

Contact Rating	50mA, 12V DC	
Contact Resistance	100mΩ max.	
Insulation Resistance	100MΩ min, 500V DC	
Dielectric Strength	250V AC/1 minute	
Operating Force	100±50gf	TL(L)-61
	160±50gf	TL(L)-62
	260±50gf	TL(L)-63
Travel	0.2mm	
Operating Life	200,000 cycles for 260gf	
	500,000 cycles for 160/100gf	
Operating Temp.	-25°C ~ +70°C	
Storage Temp.	-30°C ~ +80°C	

HOW TO ORDER

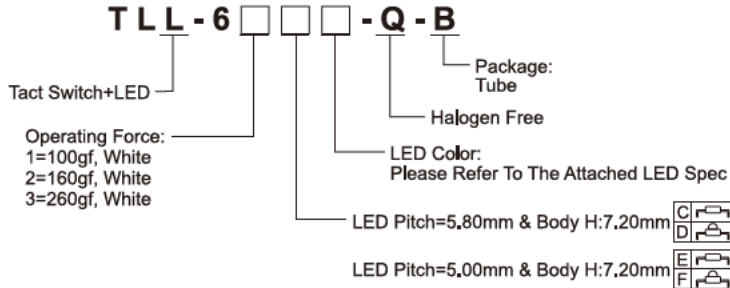

LED Color Options:

Part No.	Color	Dominant Wavelength λ _d Typ.(nm)	Luminous Intensity I _v (mcd)		Forward Voltage V _f (V)		View Angle 2θ _{1/2} (Degree)	
			Typ.	Max.	Typ.	Max.	C, E	D, F
B	Blue	470	70	1100	3.0	3.6	140°	30°
PG	Pure Green	520	160	2500	3.2	3.6		
G	Yellow Green	570	30	550	2.0	2.3		
Y	Yellow	590	60	1500	2.0	2.3		
A	Soft Orange	605	50	1500	2.0	2.3		
O	Red Orange	620	80	3000	2.0	2.3		
R	Red	630	60	1000	2.0	2.3		
W	Cold White	X:0.30 / Y:0.30	350	550	3.0	3.6		

CIRCUIT

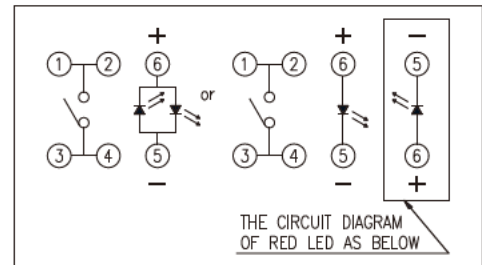

PACKAGE

<Tube>
75 pcs.

TLL-6 [] C

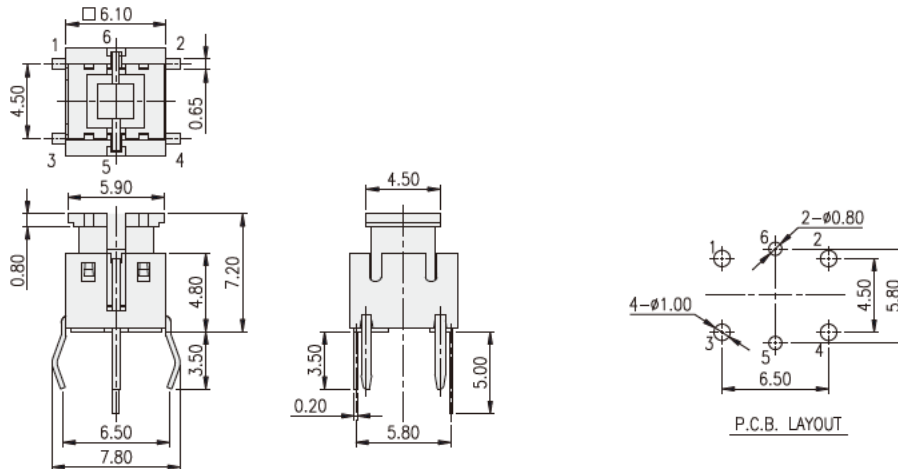

TLL-6 [] F

